

Installation and Operation Manual

FW2800 and FW2900 Series



Contents	Page
Introduction	3
Notes, Cautions, and Warnings	3
Section 1 – General Safety Instructions	4
Section 2 – Fifth Wheel Intended Use	4
Section 3 – Fifth Wheel NON-Intended Use.....	4
Section 4 – Welding Standards	5
Section 5 – Model Identification.....	6
Section 6 – General Installation Instructions	7
Section 7 – Installation Instructions	8
Section 8 – Power Take Off (PTO) and Hydraulic Pump Installation.....	12
Section 9 – Coupling Preparation	15
Section 10 – General Coupling Procedures	16

Contents	Page
Section 11 – OVER the ROAD Operation - Coupling Procedure.....	18
Section 12 – OVER the ROAD Operation – Un-Coupling Procedure	20
Section 13 – PRIVATE YARD (Yard-Spotter) Operation – Coupling	22
Section 14 – PRIVATE YARD (Yard-Spotter) Operation – Un-Coupling	23
Section 15 – Maintenance.....	25
Section 16 – Troubleshooting	26
Section 17 – Plumbing Diagrams.....	28
Section 18 – Parts Breakdown.....	32

Introduction

This manual provides the information necessary for the proper operation and maintenance of HOLLAND® FW2800/FW2900 Elevating Series Fifth Wheels.

Read this manual before using or servicing this product and keep it in a safe location for future reference. Updates to this manual, which are published as necessary, are available on the internet at www.safholland.us.

When replacement parts are required, SAF-HOLLAND® highly recommends the use of ONLY SAF-HOLLAND Original Parts. A list of technical support locations that supply SAF-HOLLAND Original Parts and an Aftermarket Parts Catalog are available on the internet at www.safholland.us or contact Customer Service at 888-396-6501.

Notes, Cautions, and Warnings

Before starting any work on the unit, read and understand all the safety procedures presented in this manual. This manual contains the terms "NOTE," "IMPORTANT," "CAUTION," and "WARNING" followed by important product information. These terms are defined as follows:

NOTE: Includes additional information to enable accurate and easy performance of procedures.

IMPORTANT: Includes additional information that, if not followed, could lead to hindered product performance.

CAUTION Used without the safety alert symbol, indicates a potentially hazardous situation which, if not avoided, could result in property damage.

⚠ CAUTION Indicates a potentially hazardous situation which, if not avoided, could result in minor or moderate injury.

⚠ WARNING Indicates a potentially hazardous situation which, if not avoided, could result in death or serious injury.

1. General Safety Instructions

Read and observe all Warning and Caution hazard alert messages in this publication. The information provided can help prevent serious personal injury, damage to components, or both.

All fifth wheel installations **MUST** be performed by a properly trained technician using proper tools and safe procedures.

IMPORTANT: You **MUST** read and understand all of the installation procedures contained in this manual before installing the fifth wheel.

WARNING Failure to follow all of the installation procedures contained in this manual could cause a hazardous condition to develop which, if not avoided, could result in death or serious injury.

IMPORTANT: Prior to operation of the fifth wheel you **MUST** be thoroughly satisfied that the fifth wheel has been properly installed on the vehicle.

WARNING Failure to properly install the fifth wheel can adversely affect performance resulting in tractor-trailer separation which, if not avoided, could result in death or serious injury.

Only SAF-HOLLAND Original Parts should be used.

A list of SAF-HOLLAND technical support locations to supply SAF-HOLLAND Original Parts can be found at: www.safholland.us or contact our customer service group at 1-888-396-6501.

Updates to this manual will be published as necessary online at www.safholland.us.

2. Fifth Wheel Intended Use

1. For pulling trailers with standard SAE kingpins which are in good condition and securely mounted or locked in position in the trailer.
2. The following fifth wheels are intended for on-road hauling applications: FW2800 and FW2900.

IMPORTANT: SAF-HOLLAND definition of on-road means driving on 100% maintained concrete or asphalt roads.

3. Within the capacities stated in SAF-HOLLAND literature.
4. As recommended in SAF-HOLLAND literature (available at www.safholland.us).

3. Fifth Wheel NON-Intended Use

1. Use with non-SAE kingpins, such as kingpins which are bent, have improper size or dimensions, not secured to maintain SAE configuration, or are installed in warped trailer bolster plates or upper coupler and fifth wheel lube plates that do not maintain the SAE kingpin dimensions. Refer to SAF-HOLLAND Service Bulletin XL-SB004-01 (available on the internet at www.safholland.us) for more information on fifth wheel lube plates.
2. Tow-away operations which damage or interfere with the proper operation of the fifth wheel.
3. The attachment of lifting devices.
4. The transport of loads in excess of rated capacity.
5. In off-road applications.

IMPORTANT: SAF-HOLLAND defines off-road as terrain on which a tractor-trailer operates which is unpaved and rough, or ungraded. Any terrain **NOT** considered part of the public highway system falls under this heading.

6. Applications other than those recommended in SAF-HOLLAND literature available at www.safholland.us.

4. Welding Standards

4.1 Scope

This specification applies to all components supplied by SAF-HOLLAND, and its products. The customer assumes full responsibility for weld integrity if weld material and procedures differ from those listed below.

4.2 Workmanship

All welding on SAF-HOLLAND products MUST be performed by a welder qualified according to the appropriate AWS standard for the weld being made or an equivalent standard. It is the responsibility of the customer to provide good workmanship when welding on SAF-HOLLAND products.

4.3 Material

Items to be welded that are made from low carbon or high-strength alloy steel are to be welded with AWS filler metal specification AWS A5.18, filler metal classification ER-70S-3, ER-70S-6 or equivalent unless specified on the installation drawing.

NOTE: Any substitution for filler material from the above standard must comply, as a minimum, with the following mechanical properties:

- Tensile Strength - 72k psi (496 MPa)
- Yield Strength - 60k psi (414 MPa)
- Charpy V Notch - 20 ft.-lbs. (27 N•m) at 0o F (-17.7o C)
- % Elongation - 22%

The recommended welding gas for gas metal arc welding (GMAW) is 90% Argon / 10% CO2. If a different gas is used, welds must comply with penetration requirements shown **(Figure 1)**. Where the installation drawing specifies different than above, the drawing shall prevail.

4.4 Procedures

Tack welds used for positioning components are to be located in the center of the final weld, where practical. Tack weld should be completely fused to the finish weld. DO NOT break arc at the end of the weld. Back up all finish welds at least 1/2" (12.7 mm) or a sufficient amount to prevent craters at the end of the weld. Where weld is shown to go around corners, it is assumed the corner represents a stress concentration area. DO NOT start or stop weld within 1" (25.4 mm) of the corner. Particular care should be taken to prevent undercutting in this area.

4.5 Weld Size

If weld size is not specified, the effective throat of the weld must be no smaller than the thinnest material being welded **(Figure 1)**.



WARNING Failure to weld correctly could cause distortion, damage, and/or result in insufficient strength and subsequent joint failure which, if not avoided, could result in death or serious injury.

Figure 1

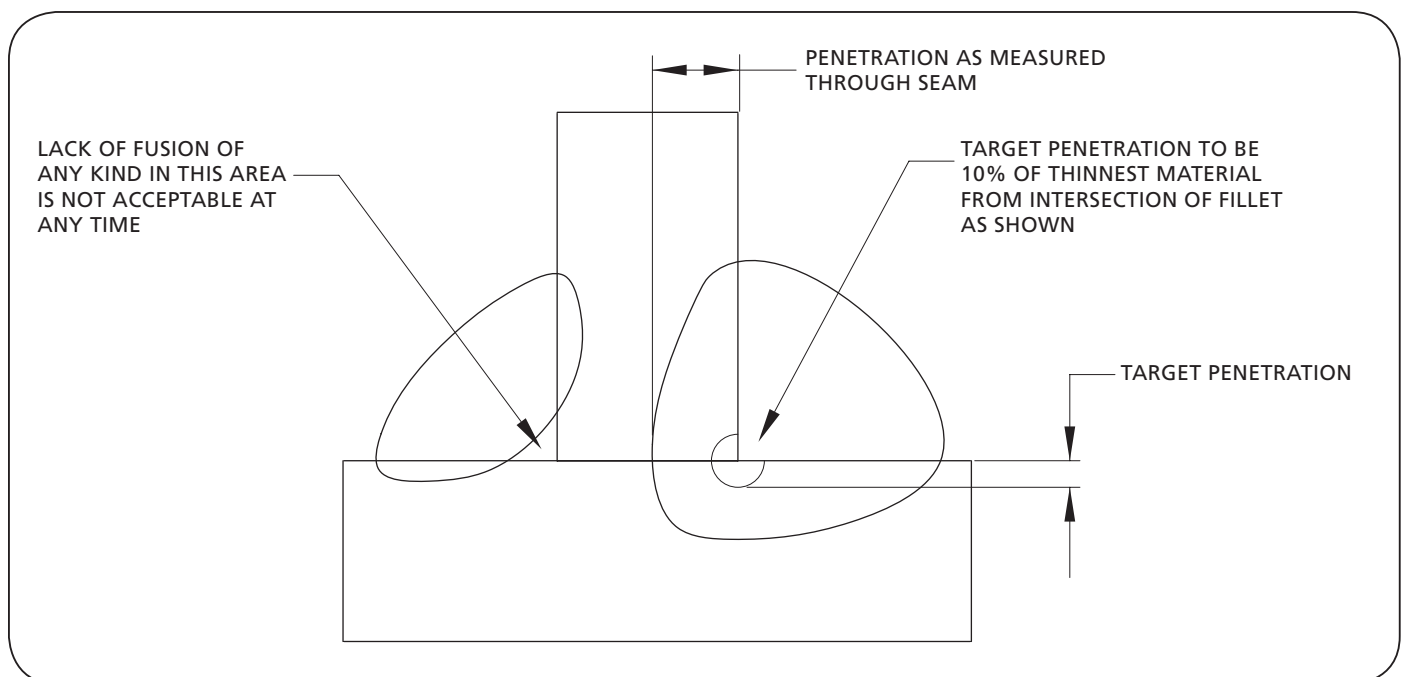

5. Model Identification

Fifth wheel serial tags are located on the handle side of the fifth wheel top plate above the fifth wheel bracket pin, or on the pickup ramps as illustrated (**Figure 2**).

The part number and serial number are listed on the tag as illustrated (**Figure 3**).

Figure 2

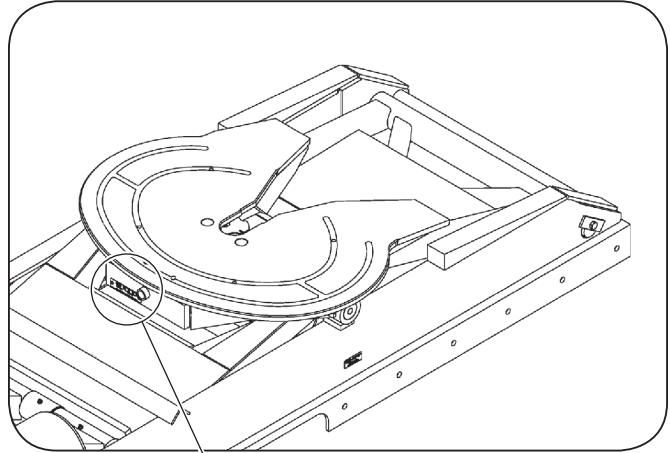
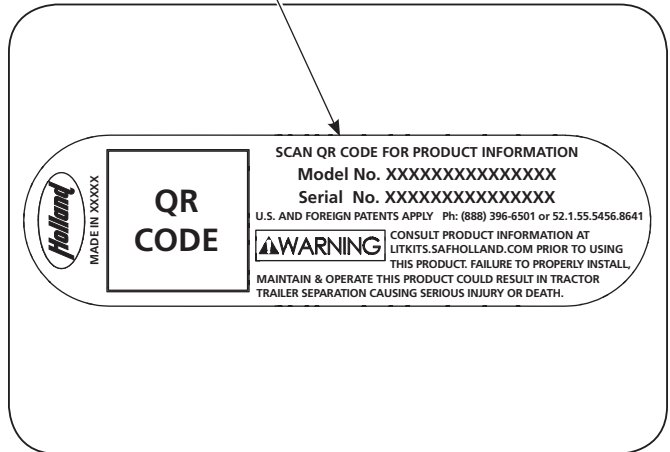

Figure 3



6. General Installation Instructions

1. Consult the HOLLAND Fifth Wheel Catalog and Specification Guide for fifth wheel capacities and applications.
2. Consult the tractor manufacturer's body builder book, the latest SAE and D.O.T. standards, and the T.M.C. Recommended Maintenance Practice 603 C for installation procedures.
3. Determine the proper fifth wheel position. Proper positioning of the fifth wheel is important for weight distribution, swing clearance, and handling characteristic. Consult SAEJ701, the tractor manufacturer's body builder book, and Section 7 of this manual.
4. Use only new Grade 8, 5/8" minimum diameter bolts and new Grade C lock nuts in all mounting holes. Larger diameter Grade 8 fasteners can be used.
5. Bolt holes can be 1/32" (0.8 mm) larger in diameter than the fastener. Bolts MUST be adequately tightened to manufacturer's torque recommendation.
6. The bolts attaching the fifth wheel mounting angles to the tractor frame require hardened steel washers under both the bolt and the lock nut, unless flanged head bolts or flanged head lock nuts are employed.
7. The distance between bolts MUST NOT exceed 8" (203 mm), except when cutouts are required in the mounting angles.
8. Bolt holes MUST be located within 4" (102 mm) from the ends of the mounting angle.
9. Mounting bolts should be located no closer than 1" (25.4 mm) from the bottom of the mounting angle to the center of the bolt hole.
10. Whenever a cutout is made on the mounting angle, such as would be required to bypass spring hangers, a 1" (25.4 mm) minimum radius should be used in the cutout, and bolts should be placed within 1-1/2" (38.1 mm), but no closer than 1" (25.4 mm) of the cut, fore and aft.
11. The entire base of the fifth wheel assembly and mounting angle members MUST be mounted flush with the top of the frame rail to prevent flexing and to give uniform weight distribution. It is recommended to chamfer or smooth sharp edges and corners of mounting materials wherever contact is made with the tractor frame.

IMPORTANT: DO NOT use U-bolts in fifth wheel installations

⚠ WARNING

Use of U-bolts in fifth wheel installations could result in catastrophic failure of the fifth wheel assembly, which if not avoided, could result in death or serious injury.

7. Installation Instructions

General Recommendations

1. Every user and installer using HOLLAND products must ensure that the installation procedure used is appropriate for the vehicle, product and application.
2. Consult the HOLLAND literature for fifth wheel capacities and applications.
3. Determine the range of proper fifth wheel positions. Proper positioning of the fifth wheel is important for weight distribution, swing clearance and handling characteristics.

WARNING The center of the kingpin locks must always be positioned on or ahead of the tractor rear axle or bogie centerline. Failure to do so can result in loss of vehicle control.

4. A minimum of 5 bolts should be applied to attach each mounting angle to the tractor frame rail, and the distance between bolts should not exceed 8", except when cutouts are required in the mounting angles (**Figure 4**).
5. Whenever a cutout is made on the mounting angle, such as required to bypass spring hangers, a 1" minimum radius should be used and bolts should be placed within 1-1/2", but not closer than 1" of the cut, fore and aft (**Figure 4**).

6. When initially positioning the fifth wheel for frame holes, the full length of the fifth wheel mounting angles should seat flush on the top and side surfaces of the truck-tractor frame rails where channel-type rails are employed. There should not be a gap over the top of the truck frame rails. The base of the fifth wheel assembly and of the mounting angle members should seat flush on the top of the frame rail to prevent flexing and to give uniform weight distribution. It is also recommended to chamfer or smooth any sharp edges and corners of mounting materials wherever contact is made with the tractor frame.
7. The bolts attaching the fifth wheel mounting angles to the truck frame require hardened steel washers under both the bolt and under the locknut, unless flanged head bolts or flanged head locknuts are employed.
8. Use Grade 8, 5/8" minimum diameter bolts and Grade "C" locknuts for mounting.
9. Bolt holes can be 1/32" larger in diameter than the bolt fastener. Bolts must be adequately tightened using charted torque ranges in foot-pounds for the recommended Grade 8, 5/8" diameter bolts. Larger diameter Grade 8 bolts and coated fasteners may be used.

Figure 4

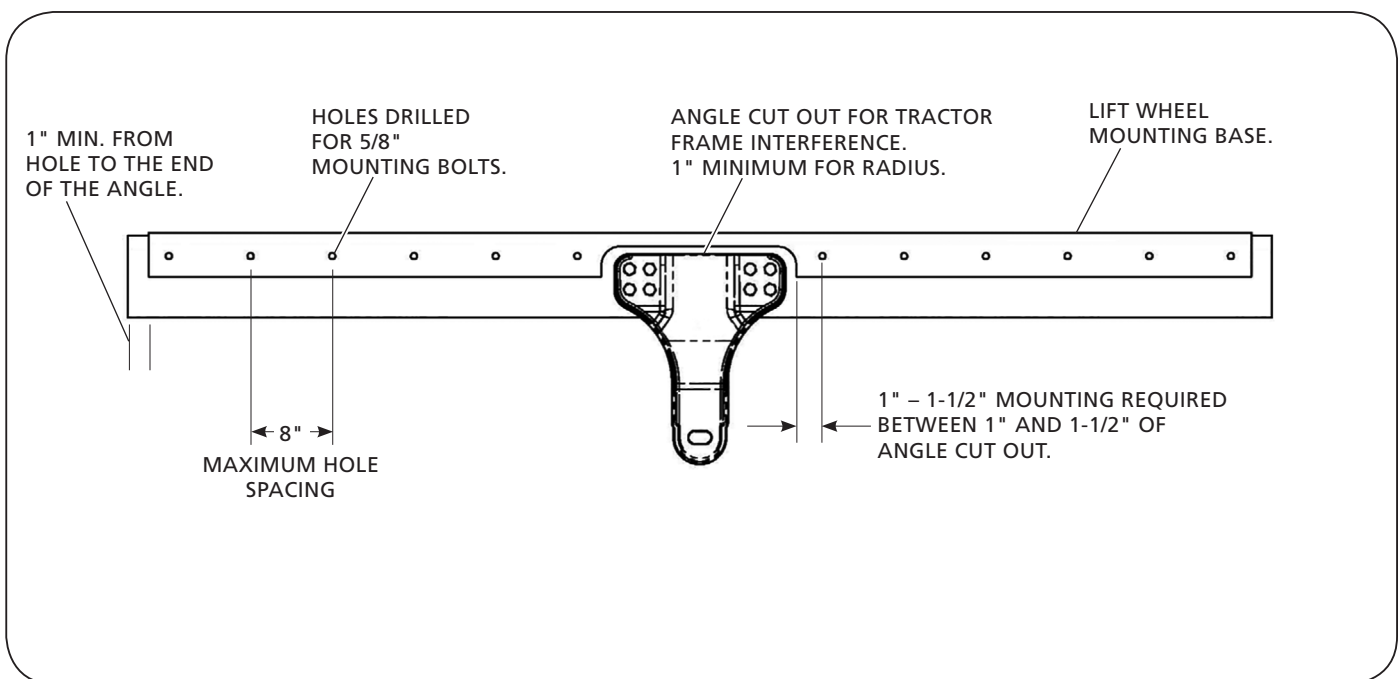

Mounting

1. Remove the shipping lugs from the bottom of the unit.
2. Determine the proper fifth wheel position on the tractor:
 - a. Verify that the tractor has sufficient "Cab to Axle" (C.A.) clearance for the elevating fifth wheel model selected, as listed in **Table 1** and **Figure 5**.
 - b. Locate the pivot point of the fifth wheel (when it's in the down position) on the given mounting angles by positioning the angles approximately 1" beyond each end of the fifth wheel assembly frame. Once this has been completed, mark the pivot point of the fifth wheel on both angles (**Figure 6**).

Table 1

Cab to Axle Requirements and Mounting Location

Model	Minimum Cab to Axle*	Mounting Location (A)
FW2800-X	72"	10"
FW2800-5X	77"	10"
FW2900-X	60"	6"
FW2900-5X	65"	7"

*Based on a 102" wide, square corner trailer, with a 36" kingpin setting. More or less cab to axle clearance may be required for other nose configurations, kingpin settings, refrigeration units, etc.

- c. Take the marked angles and position them on the tractor frame.

NOTE: The marked angles will no longer be symmetrical. It is critical to make certain that the angles are not accidentally reversed.

- d. Line up the marks of both angles with the imaginary centerline of the rear axle/bogie. Use the dimension listed under "Mounting Location (A)" in **Table 1** for the elevating fifth wheel model selected, and offset the angle forward (toward the cab) by that distance.

NOTE: The offsetting of the angles is necessary to allow for the horizontal (forward) movement of the wheel when elevating. When the wheel is in its maximum vertical condition, the pivot point of the wheel will be in line with the imaginary centerline of the rear axle/bogie and the centerline markings made on the angles in Step 2b, above (**Figure 6**).

Figure 5

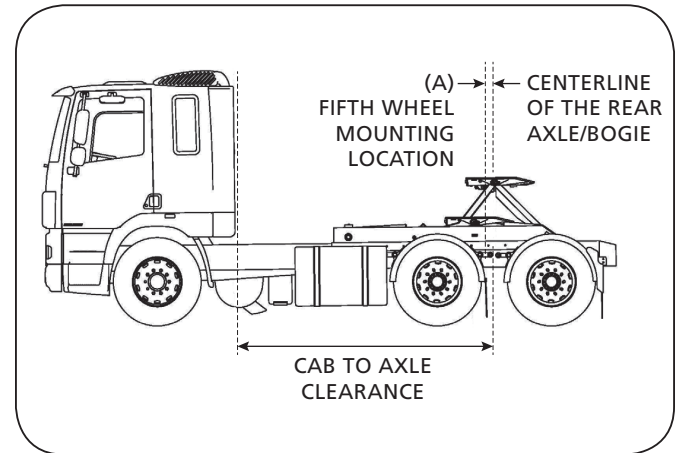
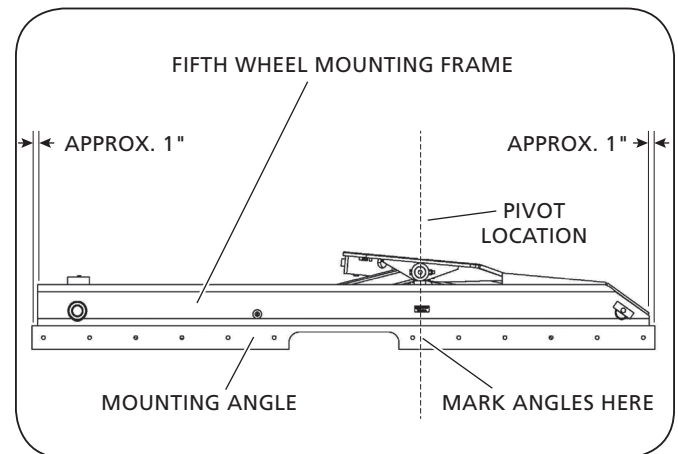

Figure 6



- Once the proper position of the angles is known, mark the angles in all areas of interference between the angles and the tractor frame. For example, mark the areas of the angle needed to be cut out to clear bolts, rivets, spring hangers, etc.

NOTE: A spacer may be required to obtain clearance between the hydraulic cylinder (and hoses) and the transmission or cross members. If a riser is needed, it may be necessary to use 5" x 5" angles.

- Remove the angles from the tractor frame and machine any interference areas in accordance with the "Installation Instructions: General Recommendations" found on the page 7.
- Clamp the mounting angles tightly to the tractor frame. Be certain to check clearances of cutouts. Drill holes in accordance with the "Installation Instructions: General Recommendations" found on the page 7.
- Remove the clamps and fasten the angles, in accordance with the "Installation Instructions: General Recommendations". In addition, refer to **Figure 8**.
- Position the fifth wheel on the mounting angles with the top plate pivot on the marked location. Verify that there are no interferences and that the fifth wheel frame seats flush on the mounting angles. Tack weld the fifth wheel to the mounting angles.
- Weld the ends of the fifth wheel assembly frame to the top of the mounting angles with two 3/8" fillet welds, as illustrated in **Figure 9**.

CAUTION

The full length of the fifth wheel mounting angle should seat flush on the truck frame when mounting to prevent flexing of mounting angle and to give uniform weight distribution along truck frame rail.

Figure 7

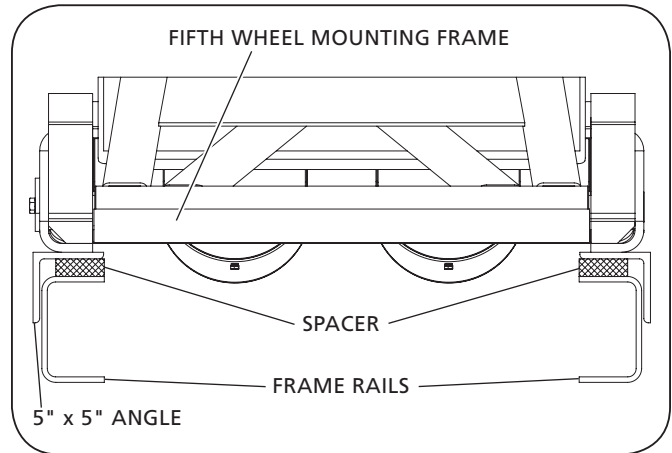

Figure 8

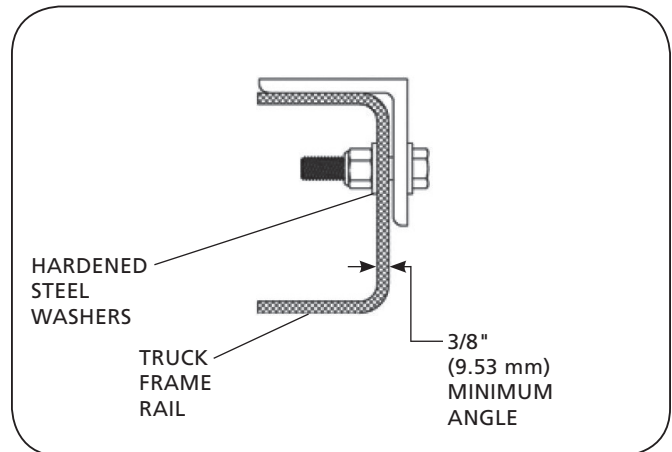
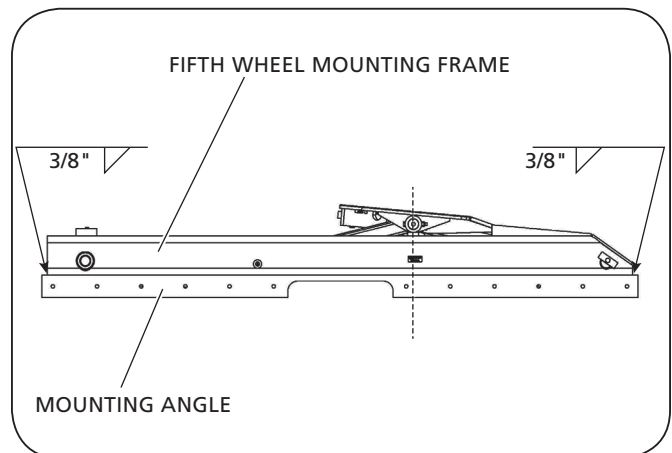

Figure 9



- Remove the rear pivot shaft (refer to corresponding fifth wheel's parts list — pages 32-35 — in combination with **Table 2** — to find the rear pivot shaft):

Table 2

Rear Pivot Shaft Identification

FIFTH WHEEL PART NUMBER	REAR PIVOT SHAFT PART NUMBER	REAR PIVOT SHAFT DETAIL NUMBER
FW2800-X	XA-2895	7
FW2900-X	XA-2895	7
FW2800-5X	XA-2895	37
FW2900-5X	XA-2895	37

- Using a lifting device, pick up the rear support assembly (refer to corresponding fifth wheel parts list in combination with **Table 3** to find the rear support assembly). For safety, block out the assembly after it is lifted.

Table 3

Rear Support Assembly Identification

FIFTH WHEEL PART NUMBER	REAR SUPPORT ASSEMBLY PART NUMBER	REAR SUPPORT ASSEMBLY DETAIL NUMBER
FW2800-X	XA-2808-B	2a
FW2900-X	XA-2908-B	2b
FW2800-5X	XA-2808-B	32a
FW2900-5X	XA-2908-B	32b

- Use air pressure to extend the cylinder rod(s) approximately 12". Be sure to cover the cylinder rod(s) to protect from weld splatter.
- Weld the fifth wheel frame to the mounting angles per **Figure 10**. Make 5/16" fillet skip welds inside the frame, and 3/8" groove skip welds on the outside. Make the skip welds 3" long on approximately 8-1/2" centers (i.e. weld 3" bead, skip 5-1/2"). Make inside skip welds opposite to the outside welds.
- Reassemble the rear pivot shaft removed in Step 9.

Figure 10

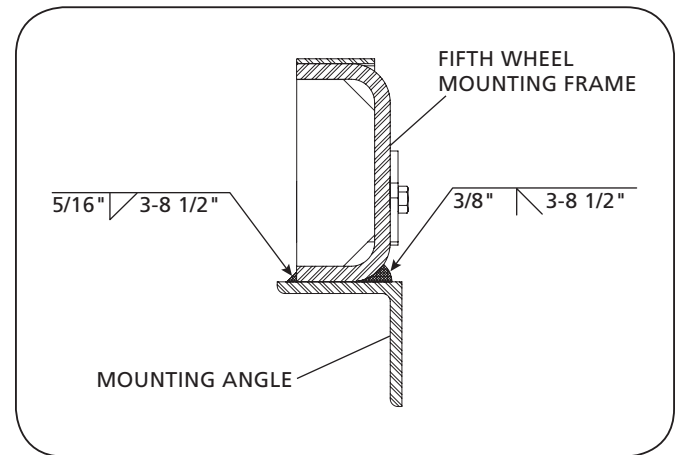

8. Power Take Off (PTO) and Hydraulic Pump Installation

General Information

1. Hydraulic fifth wheels require certain hydraulic components for operation. These components should have the following characteristics:
 - a. **Pump** – Single cylinder, 17 gallon/minute @ 1300 r.p.m.
 - b. **Power Take Off** – Compatible with transmission and pump, and with an output as close as possible to engine speed (i.e. 1-to-1 ratio).
 - c. **Hose and Fittings** – Should be of good quality and selected to handle the maximum pump output at 2,000 p.s.i.
 - d. **Hydraulic Oil** – Selection of the proper oil is a prime requirement for satisfactory system performance and life.

Detailed Information

1. Install the PTO in accordance with the PTO manufacturer's instructions. In the absence of instructions, proceed as follows:
 - a. Start the tractor and listen to the transmission. After installation the transmission should sound similar.
 - b. Shut off the tractor and drain the transmission fluid.
 - c. Remove the transmission cover plate from the PTO installation point.
 - d. Check the PTO and transmission gears for proper width, diameter, and location.
 - e. Install studs in the transmission.
 - f. Install gaskets and sufficient shims on the transmission.
 - g. Install the PTO. Draw the nuts evenly while checking the gear backlash. When fully tightened, the backlash should be .008"–.012". If the backlash is incorrect, remove the PTO and add or remove the required shims.
 - h. Check for free shifting. If free, refill the transmission to the proper level.
 - i. Install the PTO shift controls.
 - j. Start the tractor. Engage the PTO and listen to the transmission. If any unusual noises occur, inspect and correct using the shimming procedure outlined above in Step f.
2. Install the hydraulic pump per the manufacturer's recommendations.

Hydraulic Component Installation

1. Install the oil tank and brackets. The tank should be located as close to the pump as possible, with the bottom of the tank higher than the inlet port on the pump.
2. Install the hydraulic control valve.
 - a. **Manual** – Locate the valve in the cab at a convenient operation location. Then, route the hydraulic hoses through the cab to the pump, tank, and manifold.
 - b. **Air Operated** – If your unit was purchased with the optional air operated control valve kit (RK-2800-52), install as follows (refer to **Figure 11** for the following steps):
 - Mount the control valve assembly in a convenient location, between the manifold and air valve.
 - Mount the lift control valve in the cab in a location where it will not be accidentally activated.
 - With hoses, connect the air supply from a location recommended by the chassis manufacturer.

NOTE: Hose and fittings for these connections are to be supplied by the customer/installer.

- Connect the air lines from the lift control valve to the control valve.
- Connect the hydraulic hoses from the hydraulic valve to the hydraulic manifold.
- Operate the air lift control valve in both the up and down position, and inspect the hydraulic control valve. In either position, the hydraulic control valve must be fully actuated. If not, adjust the coupling until full stroke is achieved (**Figure 11**).

Figure 11

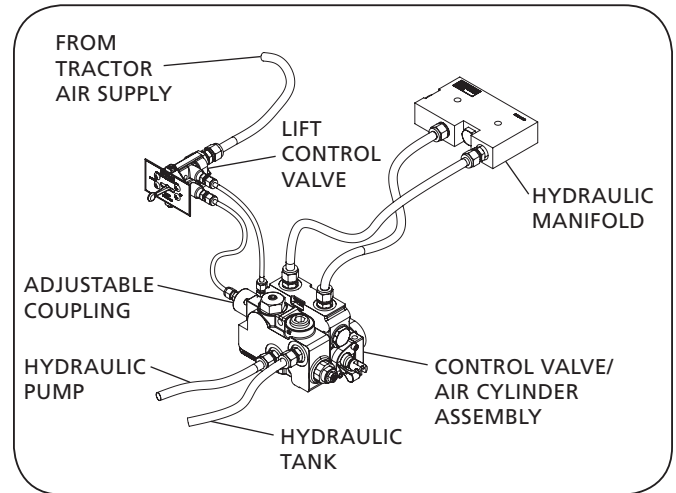

3. Install all hydraulic hoses and fittings (as illustrated in the piping diagrams on pages 28-31) for the model selected. Use care to assure that all hoses and fittings are clear and free from foreign material and that all joints are properly sealed.
4. Fill and bleed the hydraulic system.
 - a. Have, on hand, sufficient hydraulic oil for the model selected. Refer to the approximate system volumes in **Table 4**.

Table 4

MODEL	SYSTEM VOLUME
FW2800-X	7 1/2 gallons
FW2800-5X	12 gallons
FW2900-X	6 gallons
FW2900-5X	9 1/2 gallons

NOTE: These volumes are approximate and will vary somewhat from installation to installation. They are designed to provide approximately 2 1/2 gallons reserve in the oil tank when the system is filled and bled.

- b. Fill the oil tank (approximately 5 gallons), taking precautions not to let foreign material into the tank. After the tank is filled, loosen the inlet fitting on the pump until the oil drips out. Retighten the fitting. Start the engine and shift the PTO into gear. Operate the engine at 1000 to 1200 r.p.m.
 - **Single Cylinder Models** - Operate the hydraulic control valve to completely raise the fifth wheel.
 - **Twin Cylinder Models** - Operate the hydraulic control valve to raise the fifth wheel approximately one-third of its total height. Stop and refill the oil tank. Raise the fifth wheel to two-thirds total height, and again fill the oil tank. Raise to full height.
- c. Check the fluid level in the oil tank. Be sure that it contains four inches of oil (approximately half full) and add or remove oil if necessary.
- d. Take the PTO out of gear and loosen the pipe plug on the front end of the cylinder enough to let air bleed out. When oil starts to drip, retighten the plug. Engage the PTO and lower the fifth wheel.
- e. Completely raise and lower the fifth wheel. Disengage the PTO and check the oil level in the tank.

5. System Check
 - a. Double check the fifth wheel installation
 - Are all fittings tight?
 - Are all mounting bolts properly tightened?
 - Is the fifth wheel frame properly welded to the mounting angle?
 - Is the oil tank approximately half full with oil?
 - Has the transmission been refilled with transmission fluid?
 - b. Lubricate the unit. Apply Dura Slide™ or grease to the top bearing surface of the fifth wheel, and grease all of the grease fittings at pivot points in the elevating fifth wheel mechanism.
 - c. Install the operating instructions in the tractor cab.
 - d. Check the proper operation of the fifth wheel locking mechanism by coupling several times to a trailer or with a HOLLAND TF-TLN-5001 lock tester. (The lock tester may be used prior to lubricating the top plate.) Also test the operation of the manual secondary lock.
 - e. Check the operation of the system in accordance with the operating instructions by lifting, moving, and spotting a loaded trailer.
 - f. Shut the system down and check the hydraulic system for leaks. Also, examine the mechanical components to assure that there are no interferences with any components of the tractor frame.

9. Coupling Preparation

1. Prior to coupling, an inspection **MUST** be performed on the fifth wheel and mounting to verify the following:
 - Tighten loose fasteners.
 - Replace missing fasteners.
 - Repair/replace missing, cracked or otherwise damaged components.
 - Lubricate fifth wheel-to-trailer contact surfaces, if needed.
 - Inspect fifth wheel mechanism. Lubricate dry or rusty components.
 - Inspect air line connections.
 - Ensure that the fifth wheel is in the appropriate position for weight distribution on the tractor.
2. Ensure that the coupling area is flat, level, and clear of persons and obstacles.
3. Tilt the ramps of the fifth wheel downward (**Figure 12**).
4. Ensure that the locks are open. If the locks are closed, check to see if the secondary lock is engaged. If it is engaged, release it by pulling the secondary lock handle. To keep the lock open, place the handle loop end in the parking hole of the top plate. This holds the lock away from the yoke (**Figure 13**).
 - a. **Manual Release:** Pull the release handle completely out (**Figure 14**).
 - b. **Air Release:** Set the tractor parking brake and pull the fifth wheel release valve until the locking mechanism opens and locks into place. Release the pull valve. Release the tractor parking brake.
5. Visually inspect the fifth wheel throat to ensure that the locks are completely open and ready to accept the kingpin (**Figure 14**).
6. If the locks are **NOT** completely open (**Figure 14**), repeat Steps 4-6.

Figure 12

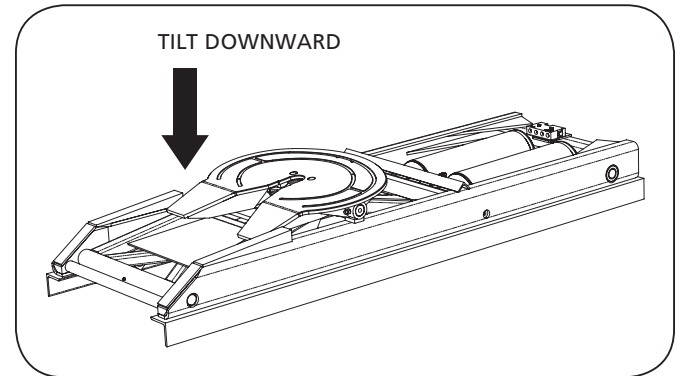

Figure 13

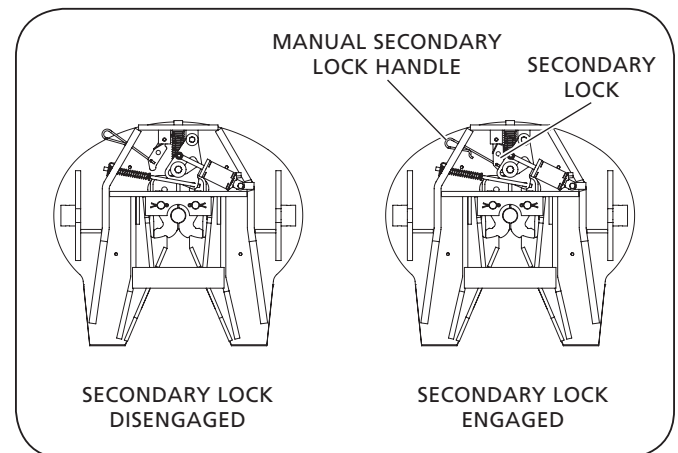
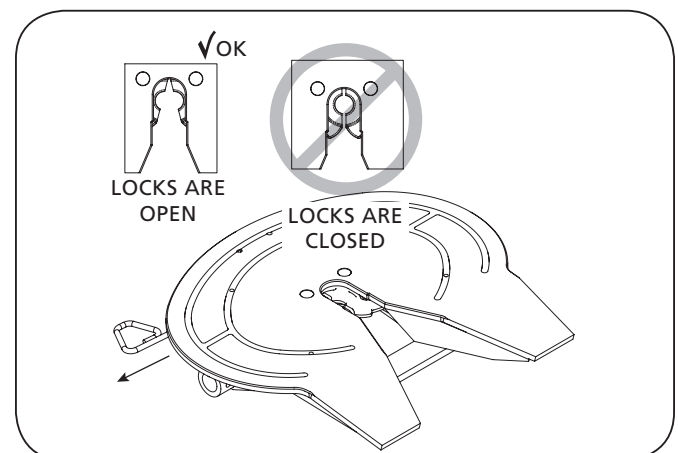

Figure 14



10. General Coupling Procedures

1. Chock the trailer wheels.
2. Position the tractor so the center of the fifth wheel is aligned with the kingpin.
3. Traveling in a straight line, slowly back the tractor to the trailer. STOP the tractor before making contact with the trailer (**Figure 15**).
4. Place the tractor into neutral and set the parking brake.
5. Completely exhaust the air from the tractor suspension, ensuring that the fifth wheel is below the contact surface of the trailer (**Figure 16**).
6. Exit the cab and ensure that the fifth wheel is below the upper coupler plate. Verify proper fifth wheel height. If the trailer is too low, use the landing gear to raise the trailer height.

NOTE: For proper operation of landing gear, follow the instructions published by the landing gear manufacturer.

7. Slowly back up, using the lowest gear possible. Stop when the fifth wheel is under the leading edge of the trailer (**Figure 17**).
8. Place the tractor into neutral and set the parking brake. Exit the cab and verify proper fifth wheel-to-kingpin alignment.
9. Adjust the tractor suspension to ride height. The fifth wheel top plate face **MUST** make contact with the upper coupler plate (**Figure 18**). If the fifth wheel **DOES NOT** make contact with the upper coupler plate, use the landing gear to lower the trailer until the fifth wheel makes contact.

IMPORTANT: If the trailer is too high, the kingpin will NOT properly connect with the lock jaws.

Figure 15

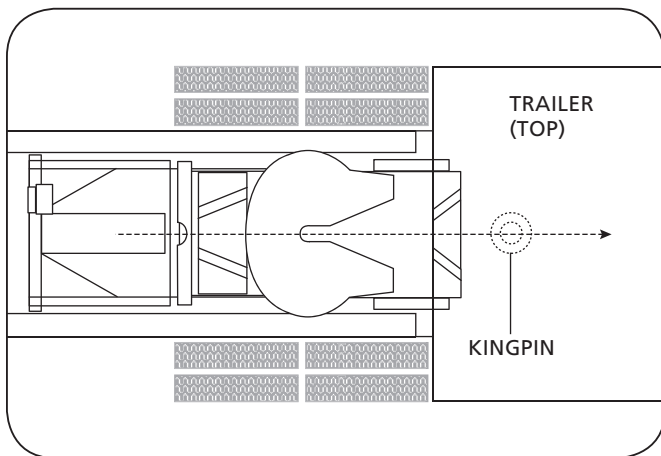

Figure 16

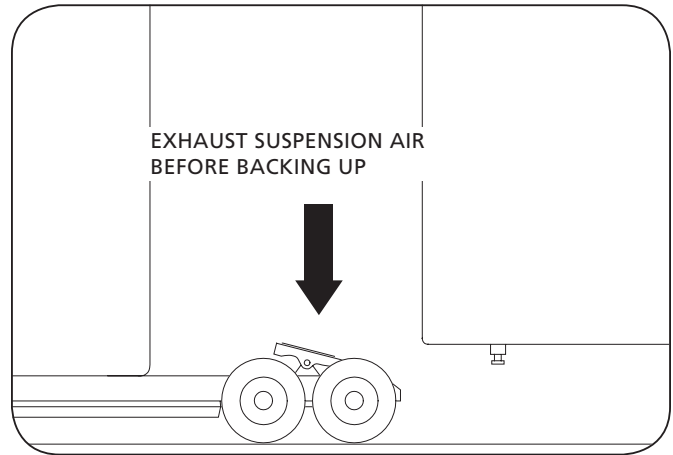

Figure 17

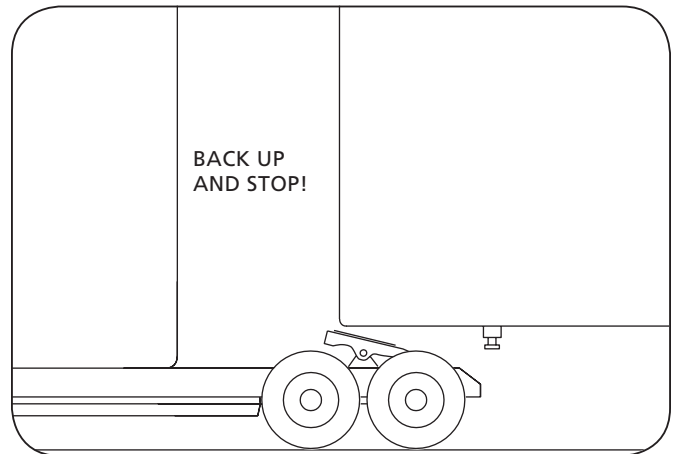
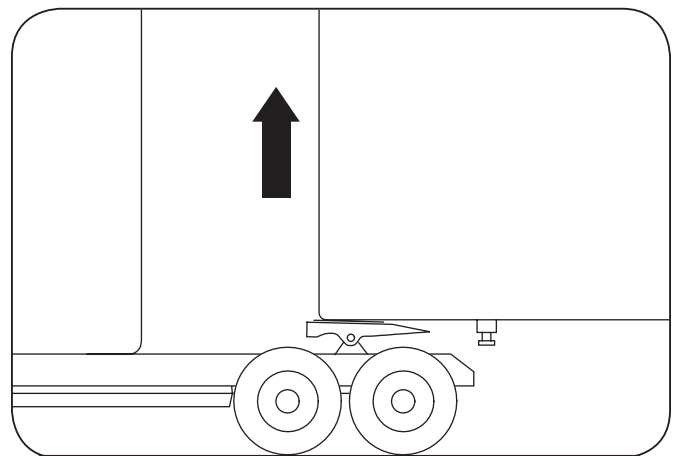

Figure 18



⚠ WARNING Failure to couple with the trailer at the proper height could result in improper coupling, allowing tractor-trailer separation which, if not avoided, could result in death or serious injury.

IMPORTANT: NEVER inflate the tractor suspension when the kingpin is above the throat of the fifth wheel.

CAUTION Failure to avoid inflating the tractor suspension when the fifth wheel is NOT forward of the kingpin, could result in damage to the kingpin and fifth wheel.

10. Slowly back into the trailer, engaging the kingpin into the fifth wheel.
11. Connect the air and electrical lines.
12. Raise the landing gear legs until the pads are just above the ground.
13. Perform a pull test as an INITIAL CHECK by locking the trailer brakes and pulling forward with the tractor to ensure that tractor-trailer separation DOES NOT occur (**Figure 19**).
14. Place the tractor into neutral and set the parking brake.
15. Exit the cab and visually inspect for the following to ensure that the lock is closed.
 - a. No gap is permissible between the trailer upper coupler plate and the fifth wheel (**Figure 20**).
 - b. Fifth wheel locks MUST be closed around the trailer kingpin (**Figure 21**).
16. If proper coupling has NOT been achieved, repeat the coupling procedure.

⚠ WARNING Failure to properly couple the tractor and trailer could result in tractor-trailer separation while in use which, if not avoided, could result in death or serious injury.

IMPORTANT: DO NOT use any fifth wheel that fails to operate properly.

⚠ WARNING Failure to repair a malfunctioning fifth wheel before use could result in tractor-trailer separation which, if not avoided, could result in death or serious injury.

Figure 19

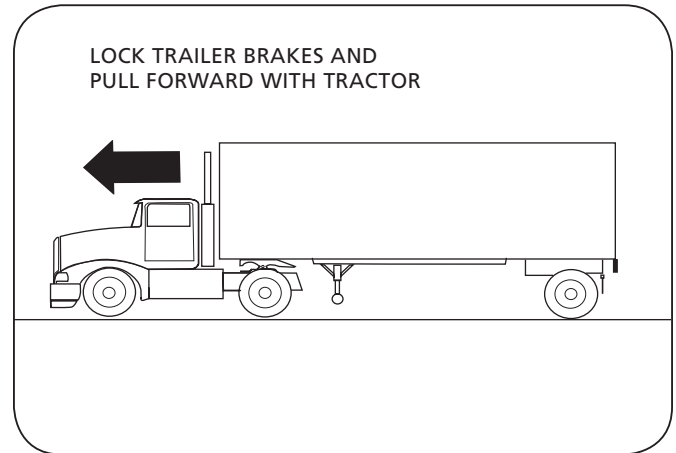

Figure 20

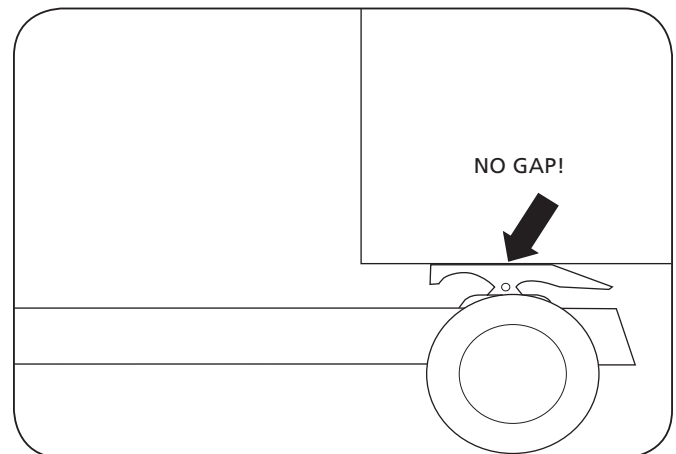
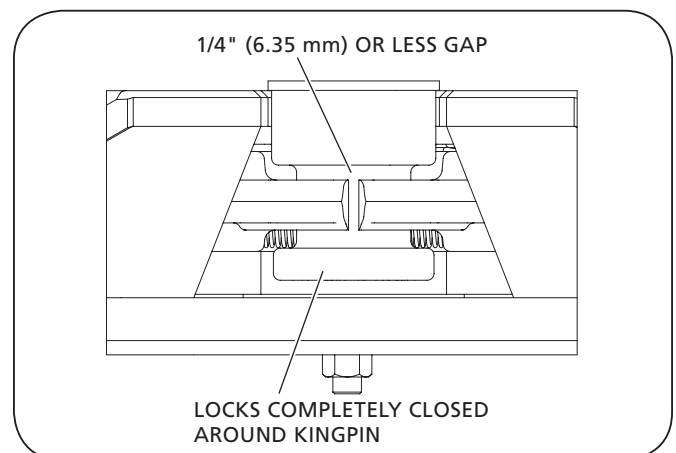

Figure 21



11. OVER the ROAD Operation - Coupling Procedure

For private yard operation (yard-spotter) coupling instructions, proceed to page 22. The two steps below are required for operation of this fifth wheel on public streets.

IMPORTANT: This unit is not intended for operation on public streets and highways with the fifth wheel in the up position. Do not operate this unit on public highways unless the fifth wheel manual secondary lock is engaged. The fifth wheel must be in the full down position and the lockdown pins (option -87) fully engaged.

WARNING Failure to lower fifth wheel to full down position and engage lockdown pins prior to moving a coupled tractor will increase vehicle instability which, if not avoided, could result in death or serious injury.

1. Unhook and engage the secondary lock for operation on public streets (**Figure 22**).
2. Place the fifth wheel in the full down position and engage the top plate lock down pins.

NOTE: The fifth wheel must be fully lowered to allow the lockdown pins to engage. If the wheel is up too high, put the transmission in neutral and engage the power take off (PTO). Set the engine speed to 1,000 to 1,200 r.p.m. and operate the control valve to lower the trailer and fifth wheel until they are all the way down.

To engage the pins, move the handle from the "Yard Use" position (handle pointing toward the front of the tractor), to the "Highway Use" position (handle pointing toward the rear of the tractor) as illustrated in **Figure 23**. This operation is also illustrated on the instruction label located directly above the handle on the left front side of the fifth wheel frame assembly (**Figure 23**).

3. **Confirm that the lockdown pins are in the extended position.** Both pins should be fully extended through the fifth wheel assembly frame rails and through the lockdown plates (**Figure 24**).

Figure 22

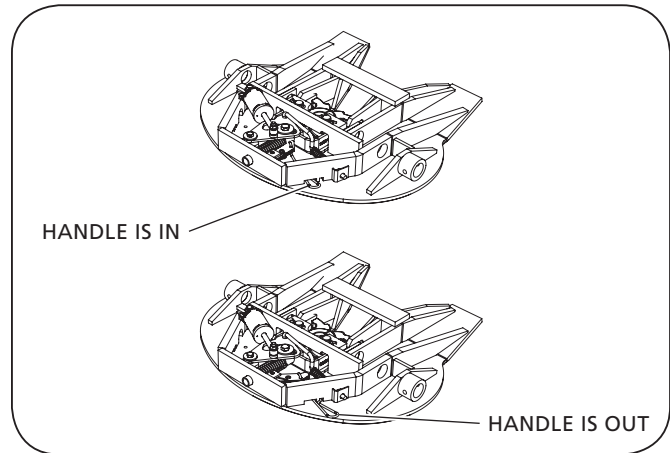

Figure 23

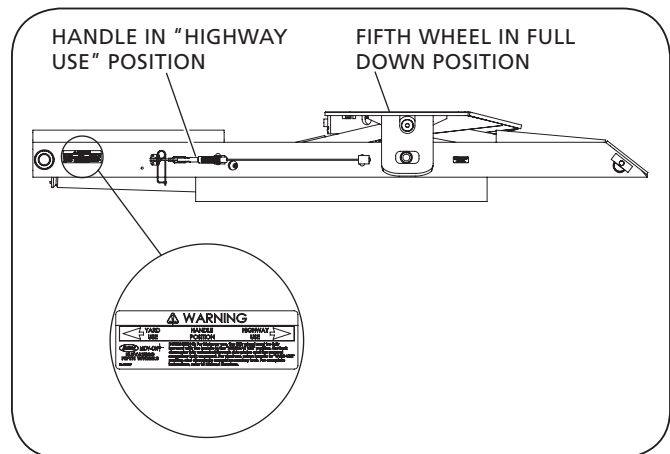
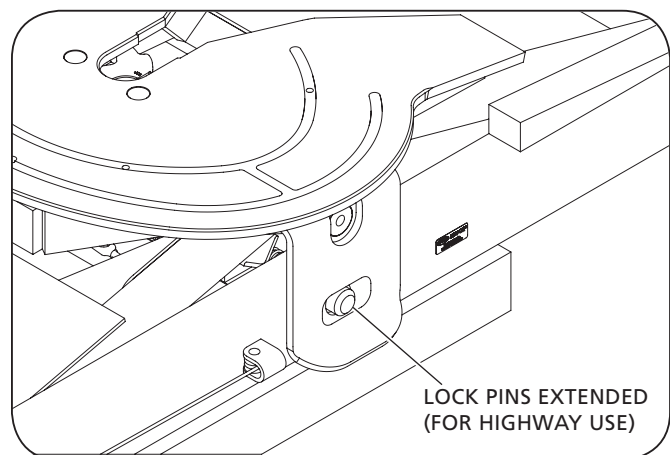

Figure 24



3. Follow the General Coupling Procedures from Section 10.
4. Fully retract the landing gear legs off the ground and secure the crank handle (**Figure 25**).

NOTE: For proper operation of landing gear, follow the instructions published by the landing gear manufacturer.

5. Remove the wheel chocks and continue with the pre-trip inspection.

NOTE: For no-tilt fifth wheels used with rigid upper couplers, always remove the no-tilt shaft assembly for on-road use.

Figure 25

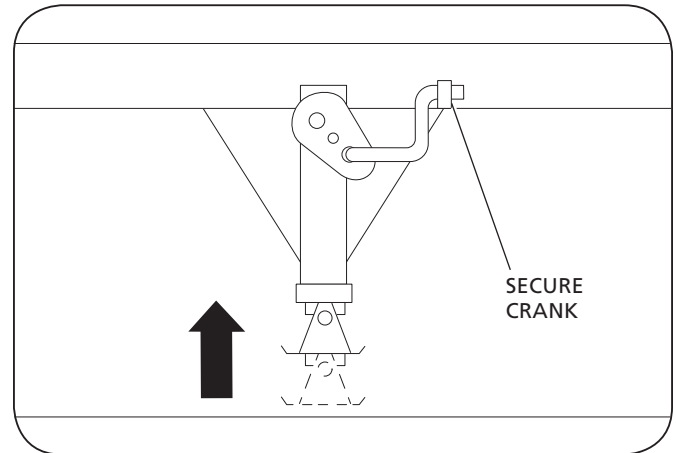

12. OVER the ROAD Operation – Un-Coupling Procedure

1. Position the tractor and trailer, in straight alignment, on firm, level ground clear of obstacles and persons.
2. Set the trailer brakes.
3. Slowly back the tractor tightly against the trailer to relieve pressure on the fifth wheel locks.
4. Place the tractor into neutral and set the parking brake.

IMPORTANT: DO NOT exhaust air from the tractor suspension before uncoupling.

CAUTION

Failure to avoid exhausting air from the tractor suspension before uncoupling could result in difficulty uncoupling the tractor from the trailer which, if not avoided, could result in damage to the fifth wheel and kingpin.

5. Chock the trailer wheels.
6. Lower the landing gear until the pads just touch the ground (**Figure 26**).

NOTE: For proper operation and ability to transfer the trailer weight from the fifth wheel, follow the instructions published by the landing gear manufacturer. DO NOT raise the trailer off of the fifth wheel.

7. Disconnect the air and electrical lines from the trailer and secure to the tractor.
8. If equipped, pull the secondary lock release handle and secure handle on handle holder (**Figure 27**).
9. Pull the release handle (**Figure 28**). If equipped with air release, pull and hold the fifth wheel release valve until the locking mechanism opens and locks into place.

Figure 26

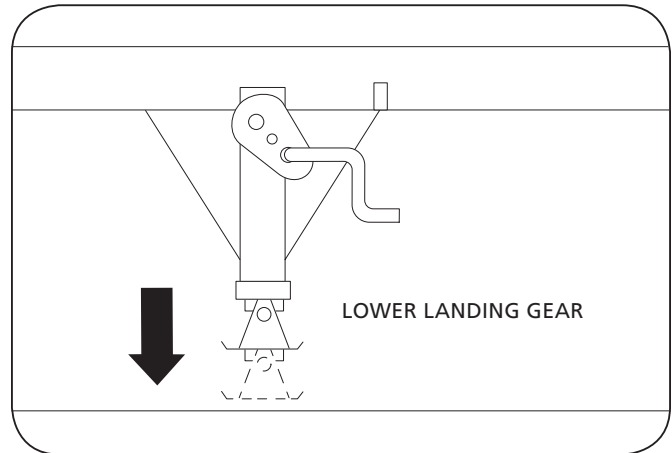

Figure 27

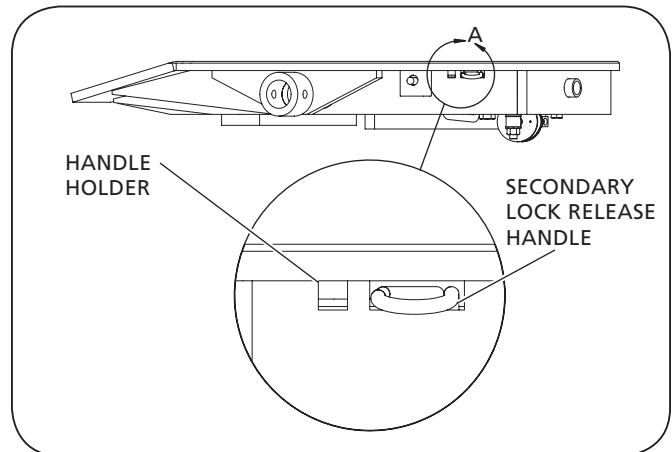
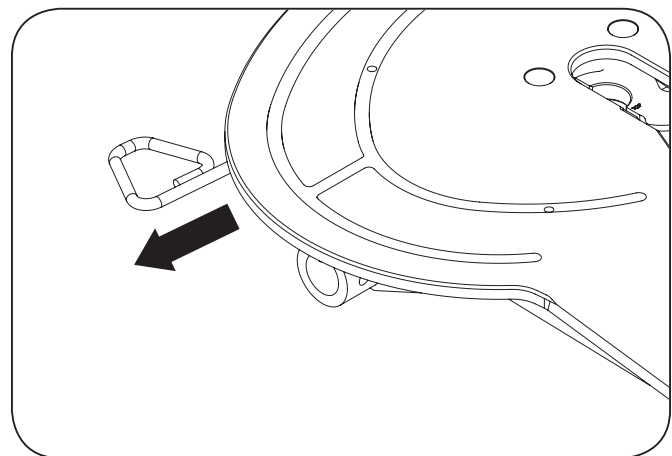

Figure 28



10. Ensure that the locking mechanism is open (**Figure 29**). If air release-equipped, ensure air pressure is exhausted from the top plate air cylinder.
11. Release the tractor parking brake and slowly pull forward 12"-18" (306-457 mm) to disengage the kingpin from the fifth wheel. The fifth wheel should be between the front edge of the trailer and the kingpin (**Figure 30**).

IMPORTANT: DO NOT drive the tractor free of the trailer.

12. Place the tractor into neutral and set the parking brake. Completely exhaust the air from the tractor suspension, ensuring that the fifth wheel is below the contact surface of the trailer (**Figure 31**).
13. Visually inspect uncoupling. Ensure that the trailer is completely supported by the landing gear.
14. Release the tractor parking brake and slowly pull away from the trailer.
15. Apply air to the tractor air suspension and allow the suspension to return to ride height (**Figure 32**).

Figure 30

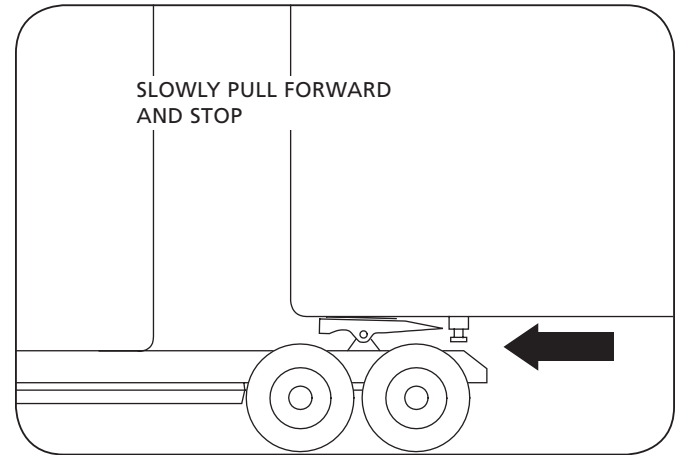

Figure 31

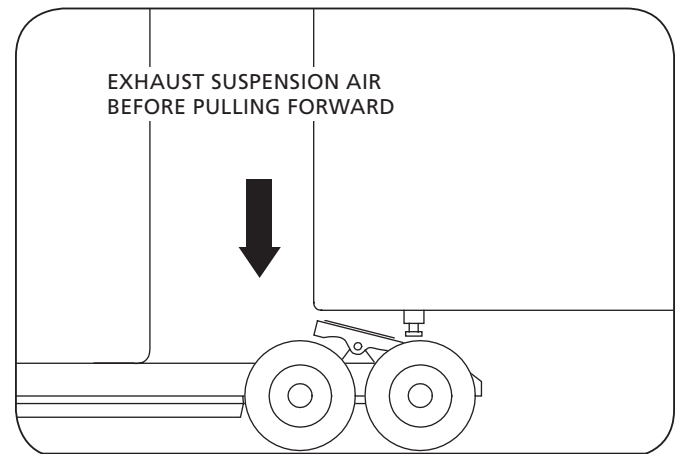

Figure 29

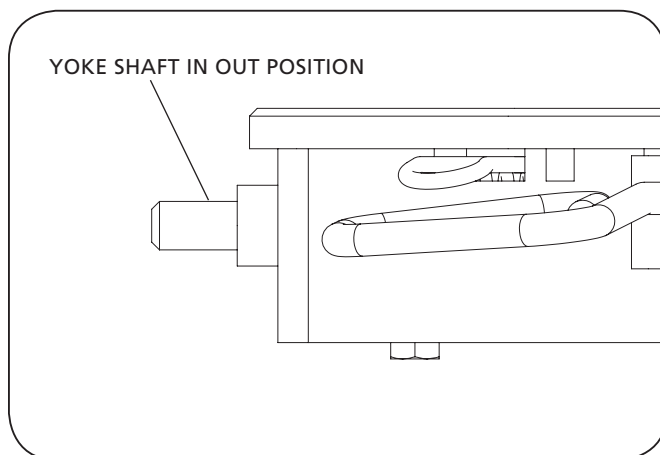
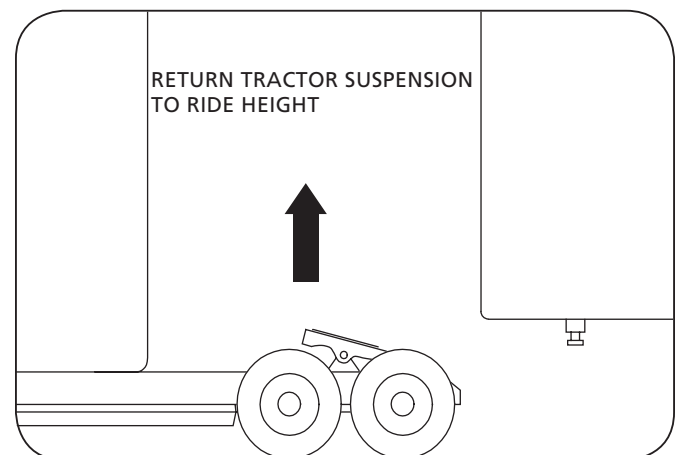

Figure 32



13. PRIVATE YARD (Yard-Spotter) Operation – Coupling

WARNING All elevating fifth wheels when towing trailers in the elevated position are less stable than conventional tractor-trailers and are sensitive to speed and maneuvers.

1. Place handle in “Yard Use” position to retract top plate lockdown pins. To retract pins, move handle from the “Highway Use” position (handle pointing toward rear of tractor), to the “Yard Use” position (handle pointing toward front of tractor) as illustrated on instruction label located above the handle on the left front side of the fifth wheel frame assembly.
2. Confirm lockdown pins are in the retracted position. Both pins should be fully retracted through the fifth wheel assembly frame rails and through lockdown plates (**Figure 33**).

Figure 33

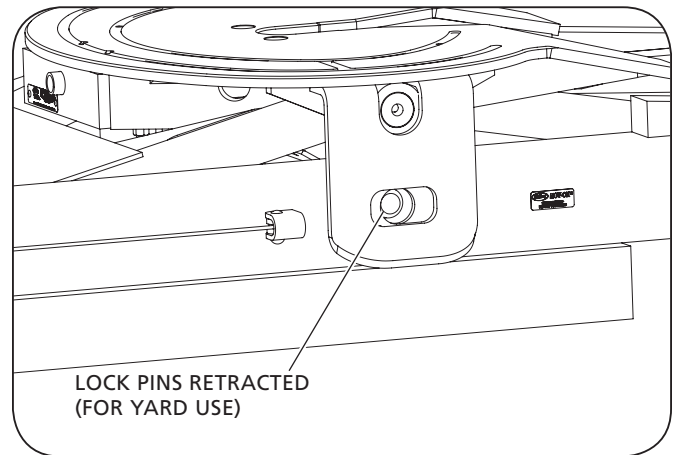

IMPORTANT: Before raising the fifth wheel, confirm that the lockdown pins are in the retracted position. Both pins should be fully retracted.

CAUTION Failure to fully retract the lockdown pins will prevent the elevator from raising when activated, which if not avoided, could result in damage to the elevator assembly.

3. Follow the General Coupling Procedures from Section 10.
4. Put transmission in neutral and engage power take-off (PTO).
5. Set engine speed to 1000 to 1200 r.p.m. and operate control valve to raise the trailer to full height of fifth wheel. Release the control lever to hold fifth wheel height.
6. Disengage PTO, remove blocks, release trailer brakes.

14. PRIVATE YARD (Yard-Spotter) Operation – Un-Coupling Procedure

1. Position the tractor and trailer, in straight alignment, on firm, level ground clear of obstacles and persons.
2. Set the trailer brakes.
3. Slowly back the tractor tightly against the trailer to relieve pressure on the fifth wheel locks.
4. Place the tractor into neutral and set the parking brake.

IMPORTANT: DO NOT exhaust air from the tractor suspension before uncoupling.

CAUTION

Failure to avoid exhausting air from the tractor suspension before uncoupling could result in difficulty uncoupling the tractor from the trailer which, if not avoided, could result in damage to the fifth wheel and kingpin.

5. Engage the PTO.

NOTE: The PTO must be engaged (pumped down) when lowering the fifth wheel.

6. Set engine speed to 1,000 to 1,200 r.p.m. and operate control valve to lower the trailer until it rests on the landing gear.
7. Disengage the PTO.
8. Chock the trailer wheels.
9. Disconnect the air and electrical lines from trailer and secure to the tractor.
10. If equipped, pull the secondary lock release handle and place the handle loop end in the parking hole of the top plate (**Figure 34**).
11. Pull the release handle (**Figure 35**). If equipped with air release, pull and hold the fifth wheel release valve until the locking mechanism opens and locks into place.

WARNING

Never push the fifth wheel lock control valve when the wheel is up or while traveling.

WARNING

Failure to lower fifth wheel to full down position and engage lockdown pins prior to pushing the fifth wheel lock control valve could result in tractor trailer separation which, if not avoided, could result in death or serious injury.

Figure 34

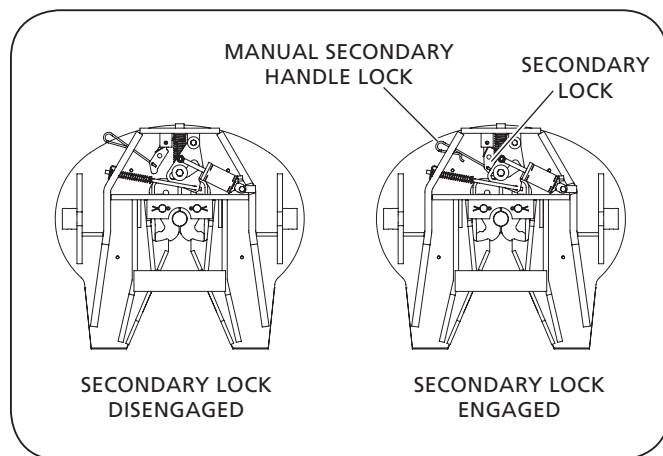
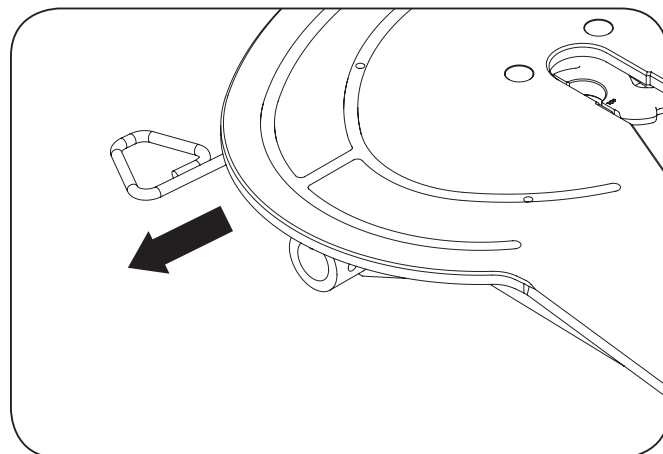

Figure 35



12. Ensure that the locking mechanism is open (**Figure 36**). If air release-equipped, ensure air pressure is exhausted from the top plate air cylinder.
13. Release the tractor parking brake and slowly pull forward 12"-18" (306-457 mm) to disengage the kingpin from the fifth wheel. The fifth wheel should be between the front edge of the trailer and the kingpin (**Figure 37**).

IMPORTANT: DO NOT drive the tractor free of the trailer.

14. Place the tractor into neutral and set the parking brake. Completely exhaust the air from the tractor suspension, ensuring that the fifth wheel is below the contact surface of the trailer (**Figure 38**).
15. Visually inspect uncoupling. Ensure that the trailer is completely supported by the landing gear.
16. Release the tractor parking brake and slowly pull away from the trailer.
17. Apply air to the tractor air suspension and allow the suspension to return to ride height (**Figure 39**).

Figure 37

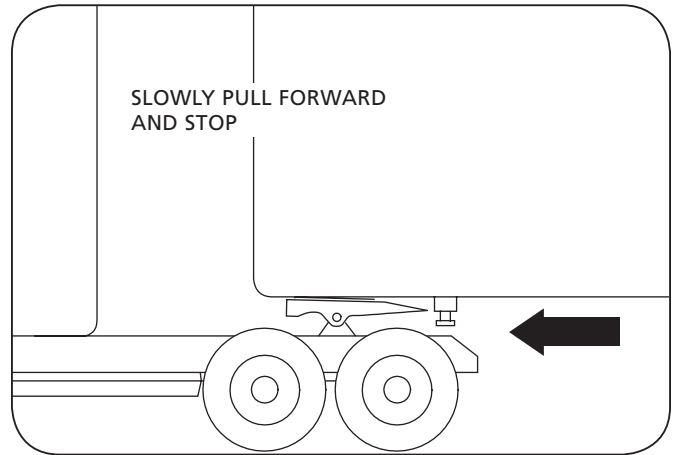

Figure 38

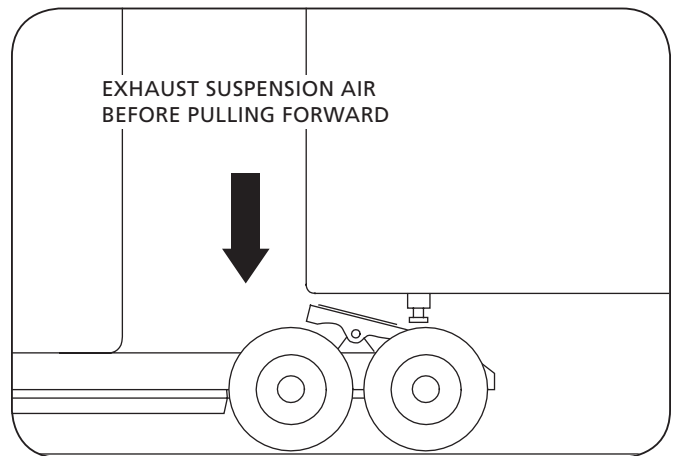

Figure 36

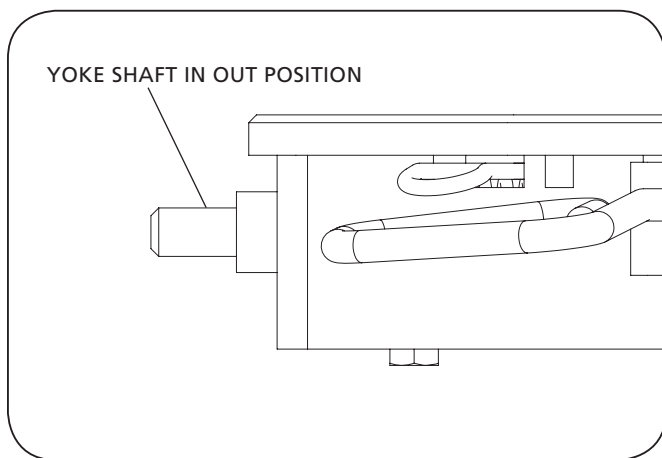
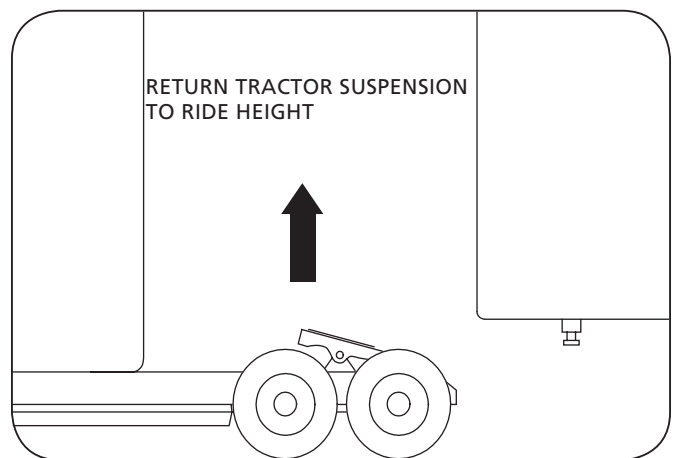

Figure 39



15. Maintenance

Top Plate

For top plate removal, lubrication and maintenance, reference SAF-HOLLAND Manual XL-FW482.

Elevating Fifth Wheel Assembly

Weekly

1. Apply grease to all 10 fittings using water-resistant lithium-based grease, **(Figure 40)**.
2. Check hydraulic oil level.
3. Check top plate lockdown mechanism cables. With handle in "Highway Use" position cable should be moderately tight and not sagging excessively. If cable is loose, rotate turnbuckle to tighten cable **(Figure 41)**.
4. After tightening, cycle handle from "Yard Use" to "Highway Use" position several times to confirm pins are extending and retracting as described above and to confirm cables are not binding or being pinched.

Monthly

1. Check the truck frame for proper bolt torque.
2. Inspect for leaks in the hydraulic system. Seal or replace any components as required.
3. Check the oil filter. Replace if necessary.
4. Check free play and pivot points in the elevating fifth wheel assembly. If free play exceeds 1/8", replace the torque frame and/or shafts as required.

Figure 40

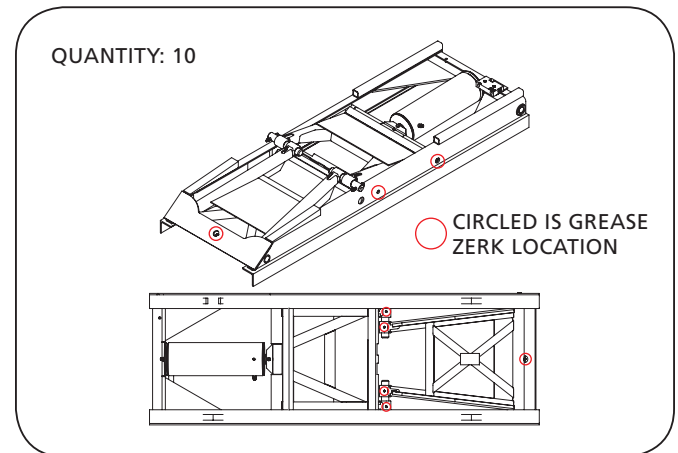
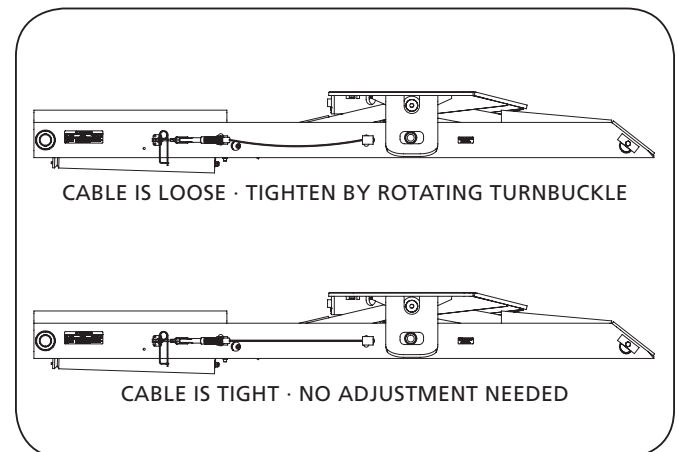

Figure 41



16. Troubleshooting

WILL NOT LIFT		
✓	POSSIBLE CAUSE	SOLUTION
	Insufficient oil	Check oil level. The tank should contain 4" of oil in the down position. If low, add oil.
	PTO not engaged	Engage the PTO. Check the shifter for proper operation.
	Engine r.p.m. too low	Increase to 1,000 to 1,200 r.p.m.
	Control valve	Check for full throw.
	Load exceeds capacity	Reduce the weight of the trailer.
	Flow restriction	Check for ruptured or collapsed hoses; check oil filter; clear the lines.
	Pump is losing prime	Raise the oil tank and/or line above the pump inlet.
	Pump is running hot	PTO left in gear; disengage when not in use.
	Oil foaming (contains air)	Tighten all fittings and check for leaks.

RAISES OR LOWERS SLOWLY		
✓	POSSIBLE CAUSE	SOLUTION
	PTO not engaged	Engage the PTO.
	Engine r.p.m. too low	Increase to 1,000 to 1,200 r.p.m.
	Control valve	Check for full throw.
	Incorrect pressure	Raising pressure circuit should be 1,800 p.s.i.; lowering circuit pressure should be 150 p.s.i.
	Flow restricted	Check for ruptured or collapsed hoses, check oil filter, clear lines.

OIL TANK IS OVERFLOWING		
✓	POSSIBLE CAUSE	SOLUTION
	Too much oil in the system	Check oil level. Tank should contain 4" of oil in the down position.
	Oil foaming (contains air)	Tighten all fittings and check for leaks.

WILL NOT LOWER		
✓	POSSIBLE CAUSE	SOLUTION
	PTO not engaged	PTO must be engaged when lowering unit.
	Engine r.p.m. too low	Increase to 1,000 to 1,200 r.p.m.

WILL NOT STAY IN RAISED POSITION		
✓	POSSIBLE CAUSE	SOLUTION
	Pressure loss	Air in hydraulic oil. Let stand until clear. Tighten fittings and check for leaks. Check oil level.
	Pressure loss	Leak in system. Tighten fittings and check for leaks.
	Pressure loss	Damaged hydraulic cylinder. Isolate and pressurize to check. Repair or replace.
	Pressure loss	Faulty valves. Clean and reassemble, or, replace control and release valves in manifold.

CRACKING OR BREAKING OF LIFT ARMS		
✓	POSSIBLE CAUSE	SOLUTION
	Rough terrain	Improve road surface.
	Overload	Reduce trailer weight.
	Lack of lubrication	Lubricate per maintenance instructions.
	Worn shafts, bushings, or housings	Replace.
	Incorrect pressure	Lifting circuit pressure should be 1,800 p.s.i.

FIFTH WHEEL WILL NOT UNLOCK PROPERLY		
✓	POSSIBLE CAUSE	SOLUTION
	Accumulated grease and dirt in mechanism	Refer to Fifth Wheel Operations Manual XL-FW482
	Insufficient lubrication	Refer to Fifth Wheel Operations Manual XL-FW482
	Faulty release air cylinder	Refer to Fifth Wheel Operations Manual XL-FW482
	Worn or damaged parts	Refer to Fifth Wheel Operations Manual XL-FW482

17. Plumbing Diagrams

FW2800-X AND FW2900-X SINGLE CYLINDER ELEVATING FIFTH WHEEL

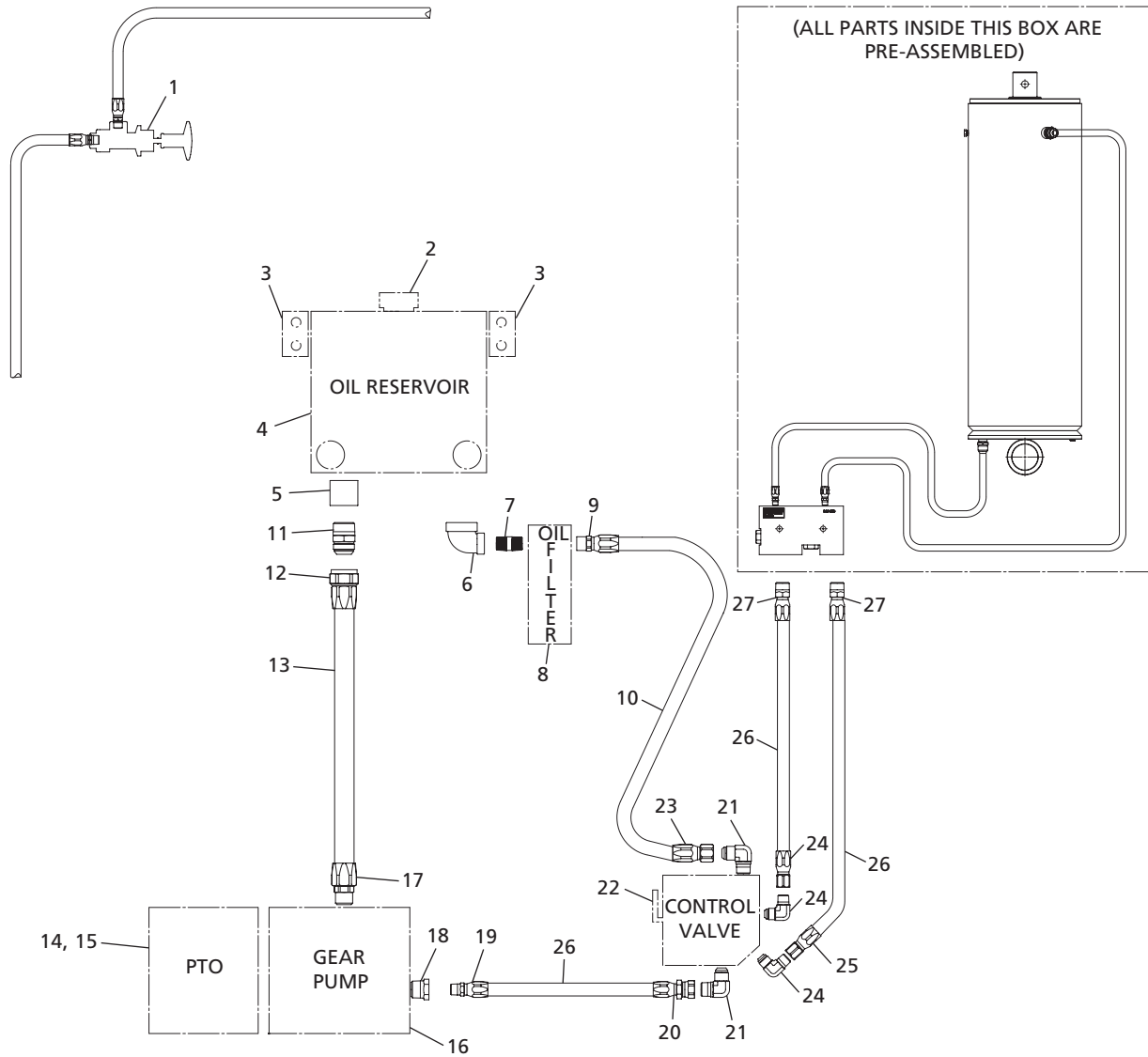

HYDRAULIC LIFT REBUILD KITS + ACCESSORIES

- *RK-2800-11-G - HYDRAULIC CONTROL VALVE FOR ALL SINGLE CYLINDER MODELS
- *RK-2800-20-G - HOSE AND FITTING FOR SINGLE CYLINDER MODELS
- *RK-2800-52 - AIR OPERATED LIFT CONTROL FOR ALL MODELS (OPTIONAL)

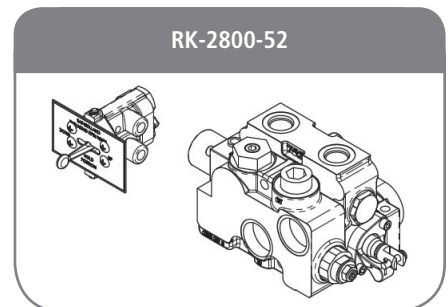

ITEM	PART NO.	QTY	DESCRIPTION
1	XB-2556	1	Valve, air control
2	XB-01786	1	Filler cap and breather
3	XA-01909	2	Bracket, mtg.
4	XB-01730	1	Oil tank-10.2 gal.
5	XB-02208	1	1 1/4" pipe coup.
6	XB-02209	1	Elbow, 90° 3/4" npt to 1-1/4" npt
7	XB-2798-1	1	Nipple, 3/4" pipe x 2" lg
8	XB-2783	1	Filter, hydraulic oil
9	XB-2793	1	Fitting, straight male hose 3/4 - 14
10	XB-2785	1	Hose, med pressure hydral 66" ID 0.62
11	XB-2790	1	Male pipe adapter
12	XB-2795	1	Fitting, SAE 37° (JIC) swivel 1-5/8-12
13	XB-2786-1	1	Hose, med. pressure hydral 66" ID 1.12
14	XB-2781-1	1	*Optional* power take off
15	XB-2781-1-A	1	*Optional* power take off w/ air operated shifter
16	XB-04476	1	*Optional* pump, hydraulic gear
17	XB-2794-1	1	Fitting, straight male hose 1 - 11-1/2
18	XB-04478	1	Bushing, reducer
19	XB-2791	1	Fitting, straight male hose 1/2 - 14
20	XB-2937	1	Fitting, SAE 37° (JIC) swivel 1-1/16-12
21	XB-2934	2	Connector, 90° male elbow
22	XB-2782-MAN	1	Control valve
23	XB-2932	1	Fitting, SAE 37° (JIC) swivel 1-1/16-12
24	XB-2939	2	90° male elbow
25	XB-2938	2	Fitting, SAE 37° (JIC) swivel 7/8-14
26	XB-2784	3	Hose, med pressure hydral 120" ID 0.50
27	XB-2792	2	Fitting, straight male hose 3/4-14

* Items 2, 3, and 4 are available individually or as XA-01911 tank assembly.

* Item 22 can be replaced with RK-2800-52. Refer to **Figure 11**.

* Kit RK-2800-11-G contains items 16, 22

* Kit RK-2800-20-G contains items 5, 6, 7, 9, 10, 11, 12, 13, 17, 18, 19, 20, 21, 23, 24, 25, 26, 27

FW2800-SX and FW2900-5X TWIN CYLINDER ELEVATING FIFTH WHEEL

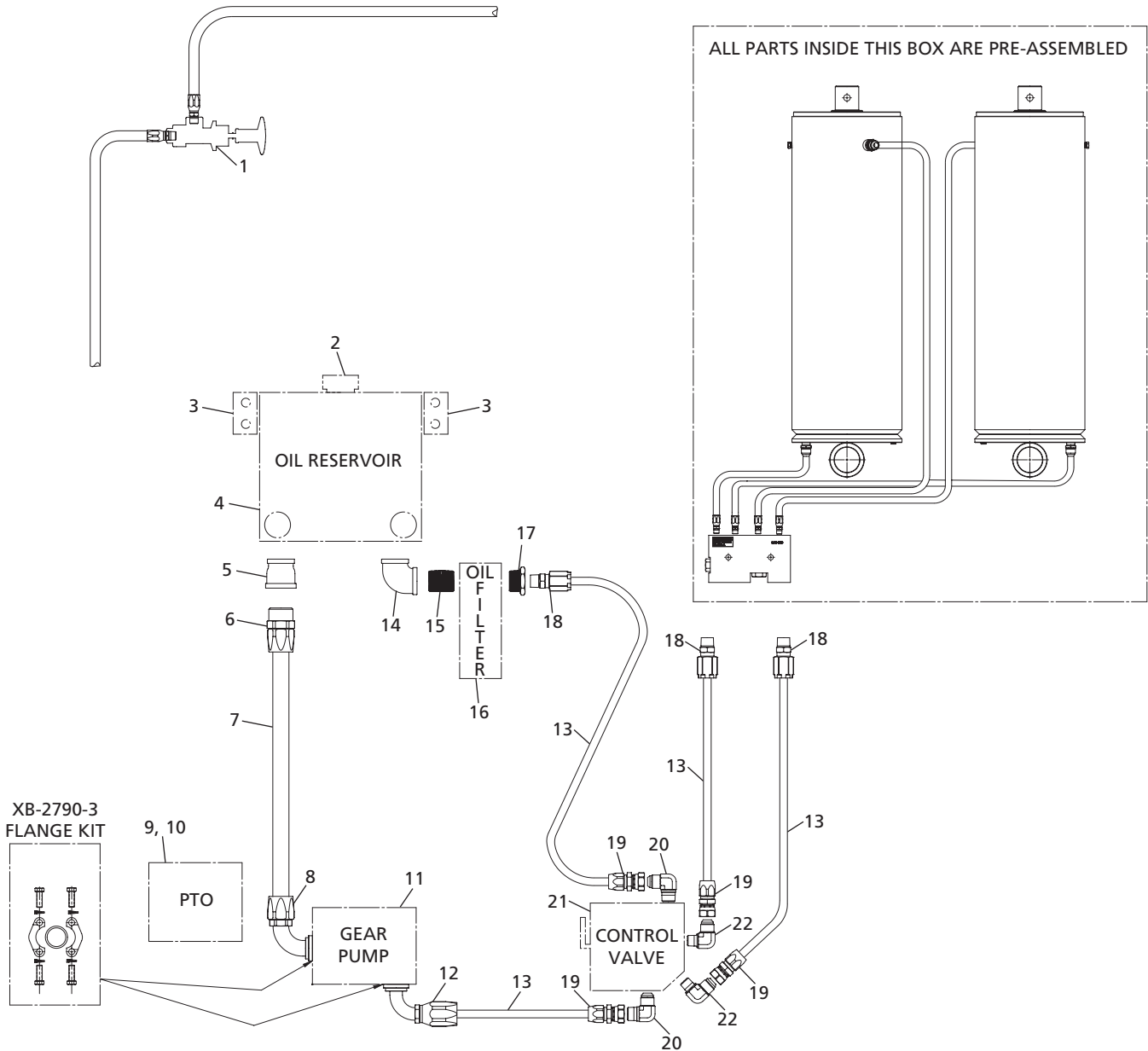

HYDRAULIC LIFT REBUILD KITS + ACCESSORIES

*RK-2800-41-G - HYDRAULIC CONTROL VALVE AND FLANGE KITS FOR TWIN CYLINDER MODELS

*RK-2800-30-G - HOSE AND FITTINGS FOR TWIN CYLINDER MODELS

*RK-2800-52 - AIR OPERATED LIFT CONTROL FOR ALL MODELS (OPTIONAL)

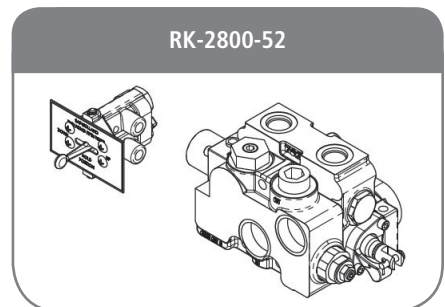

ITEM	PART NO.	QTY	DESCRIPTION
1	XB-2556	1	Valve, air control
2	XB-01786	1	Filler cap and breather
3	XA-01909	2	Bracket, mtg.
4	XB-01730	1	Oil tank-10.2 gal.
5	XB-01924	1	1 1/4" pipe coup.
6	XB-0257	1	Fitting, straight male hose
7	XB-2786	1	Hose, medium pressure hydral.
8	XB-04479	1	Fitting, 90° split flange
9	XB-2781-1	1	*Optional* power take off
10	XB-2781-1-A	1	*Optional* power take off w/ air operated shifter
11	XB-04477	1	*Optional* pump, hydraulic gear
12	XB-04480-1	1	Fitting, 90° split flange
13	XB-2785-2	1	Hose, high pressure hydral.
14	XB-01788	1	Elbow, 90° 1-1/4
15	XB-0255	1	Nipple, pipe
16	XB-2783-A	1	Filter, hydraulic oil
17	XB-0181	1	Bushing pipe 1-1/4" x 3/4"
18	XB-2794-2	1	Fitting, straight male hose
19	XB-0258-1	1	Fitting, 37° swivel
20	XB-2934	1	Connector, 90° male elbow
21	XB-2782-MAN	2	Control valve
22	XB-2933	1	Connector, 90° male elbow

* Items 2, 3, and 4 are available individually or as XA-01911 tank assembly.

* Item 21 can be replaced with RK-2800-52. Refer to **Figure 11**.

* Kit RK-2800-41-G contains items 11, 21

* Kit RK-2800-30-G contains items 5, 6, 7, 8, 12, 13, 14, 15, 17, 18, 19, 20, 22

18. Parts Breakdown

FW2800-X, FW2900-X, FW2800-X-87 and FW2900-X-87
SINGLE CYLINDER ELEVATING FIFTH WHEEL

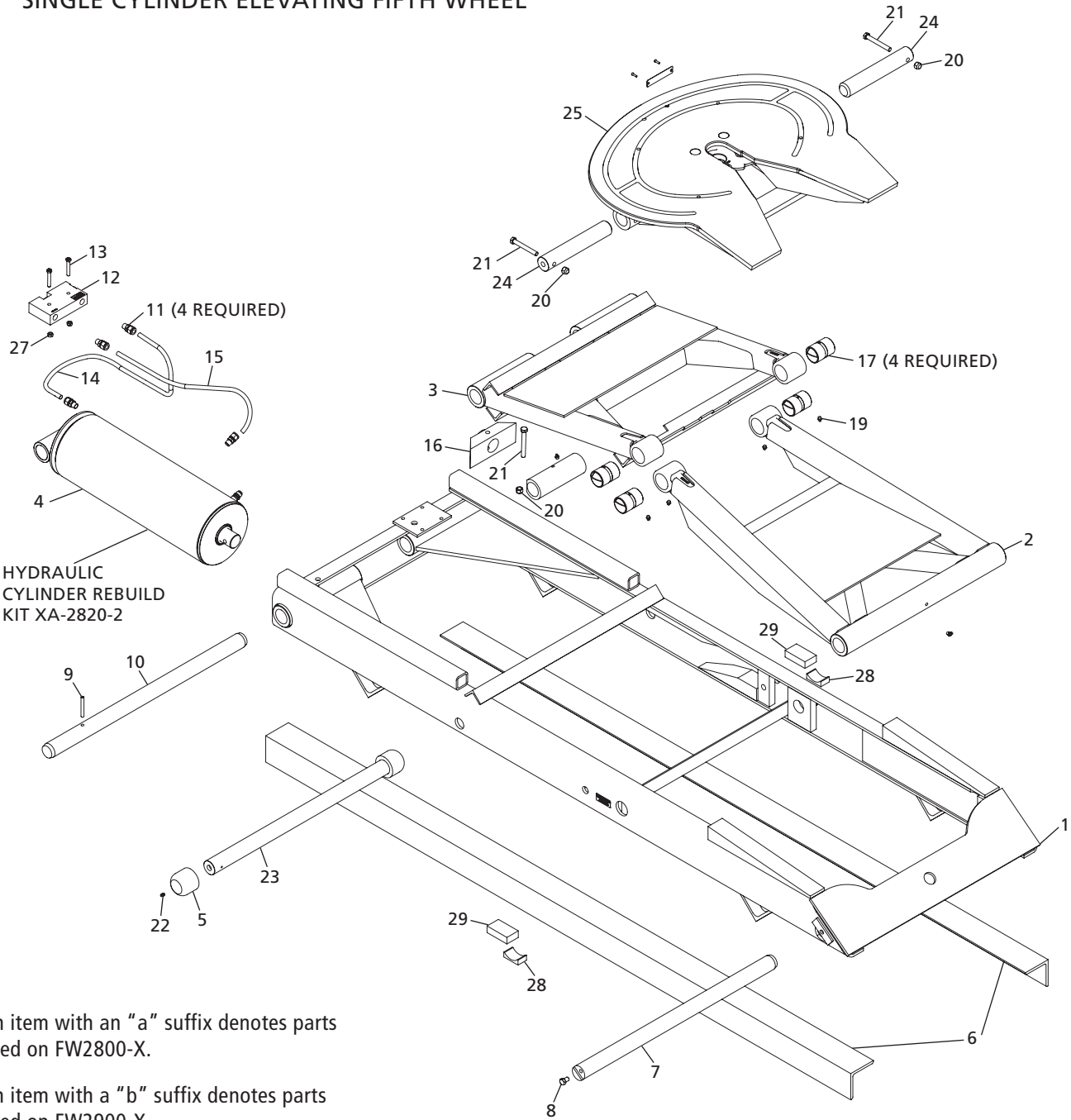

* An item with an "a" suffix denotes parts used on FW2800-X.

An item with a "b" suffix denotes parts used on FW2900-X.

An item with a "c" suffix denotes parts used on FW2900-X-87.

An item with a "d" suffix denotes parts used on FW2800-X-87.

ITEM	PART NO.	QTY	DESCRIPTION
1a*	XA-2806-2	1	Frame S/A
1b*	XA-2906		
1c*	XA-06288		
1d*	XA-08172		
2a*	XA-2808-B	1	Support S/A, rear
2b*	XA-2908-B		
2c*	XA-2908-B		
2d*	XA-2808-B		
3a*	XA-2807-B	1	Support S/A, front
3b*	XA-2907-B		
3c*	XA-2907-B		
3d*	XA-2807-B		
4a*	XA-2810-1	1	Cylinder S/A, hydraulic
4b*	XA-2710-1		
4c*	XA-2710-87		
4d*	XA-2810-87		
5a*	XA-2756-2	1	Wheel
5b*	XA-2756-3		
5c*	XA-2756-3		
5d*	XA-2756-2		
6a*	XA-292-14		
6b*	XA-292-12	1	Mounting angles
6c*	XA-292-12		
6d*	XA-292-14		
7	XA-2895		
8	XB-6834	1	HHCS, 1/2"-20 x 3/4" lg.
9	XB-21-S-375-3000	1	Pin, spring 3/8" x 3"

ITEM	PART NO.	QTY	DESCRIPTION
10	XA-2894	1	Shaft, front pivot
11	XB-2928	4	Connector, male
12	XB-2930	1	Manifold, hydraulic piping
13	XB-C-38-C-214	2	HHCS, 3/8"-16 x 2-1/4"
14	XB-2936	1	Hose assy
15	XB-2936-1	1	Hose assy
16	XA-2811	1	Clevis S/A
17	XA-0861	4	Bearing
18	XB-H-38-C	1	Fitting, lube 45°
19	XB-H-38	5	Fitting, lube
20	XB-0103	3	Nut, lock, 1/2"-13
21	XB-BR-12-C-4	3	HHCS, 1/2"-13 x 4"
22	XB-767	2	Fitting, lube
23	XA-2893	1	Shaft, axle
24	XA-2809	2	Shaft, pivot
25a*	XA-2801-AX-1	1	Plate S/A, fifth wheel
25b*	XA-2801-AX-1		
25c*	XA-2801-07486-1		
25d*	XA-2801-07486-1		
26	RK-2774	N/A	Kit rod bearing (XA-2710-1 XA-2810-1)
27	XB-338	2	Nut, lock, 3/8"-16
28c*	XA-06245	2	Pad, rest
28d*	XA-06245		
29c*	XA-09498	2	Block, riser
29d*	XA-09498		

FW2800-SX and FW2900-5X TWIN CYLINDER ELEVATING FIFTH WHEEL

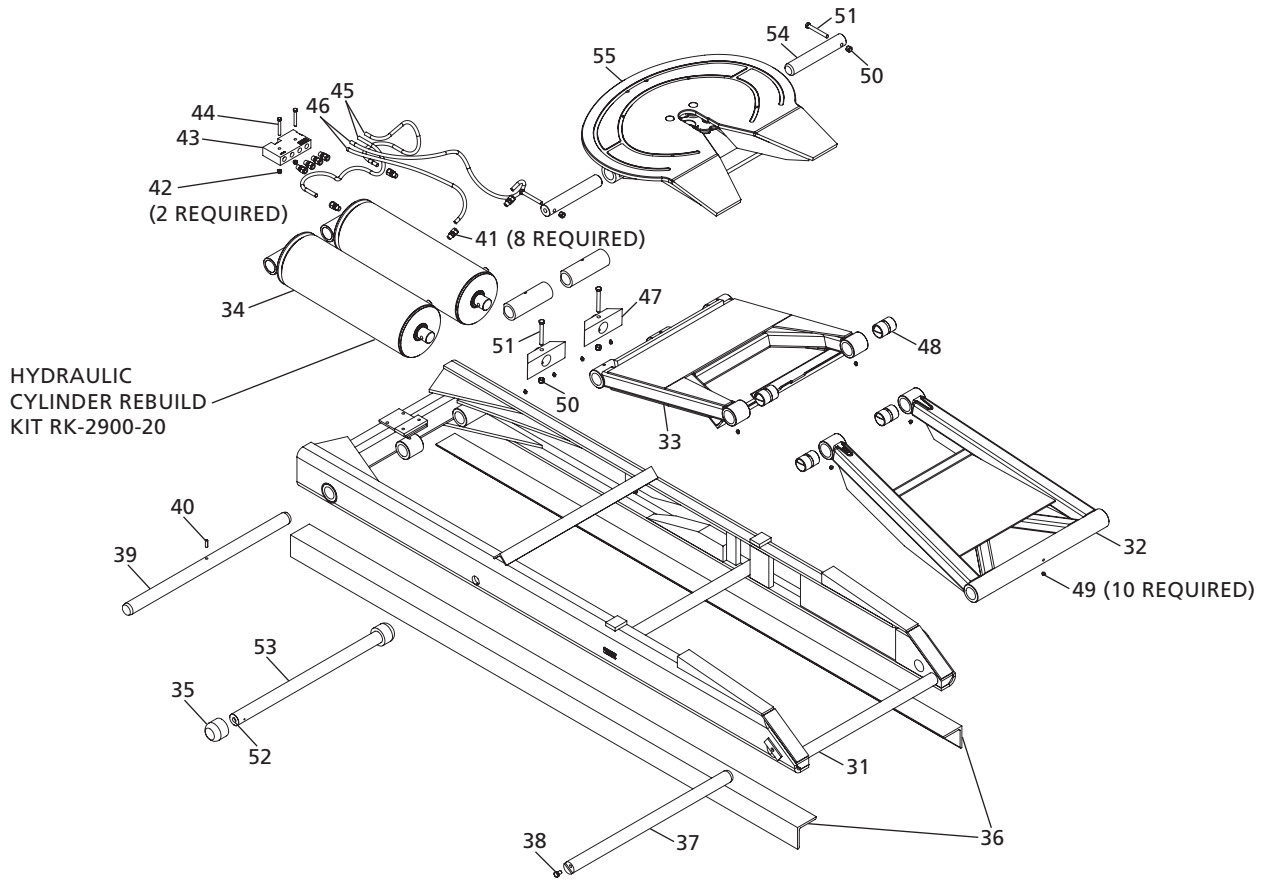

* An item with an "a" suffix denotes parts used on FW2800-5X.
 An item with a "b" suffix denotes parts used on FW2900-5X.

ITEM	PART NO.	QTY	DESCRIPTION
31a	XA-2806-2	1	Frame S/A
31b	XA-2906-1		
32a	XA-2808-B	1	Support S/A, rear
32b	XA-2908-B		
33a	XA-2807-2-B	1	Support S/A, front
33b	XA-2907-1-B		
34a	XA-2810-1	2	Cylinder S/A, hydraulic
34b	XA-2710-1		
35	XA-2756-2	2	Wheel
36a	XA-292-10	2	Mounting angle
36b	XA-292-15		
37	XA-2895	1	Shaft, rear pivot
38	XB-6834	1	HHCS, 1/2" -20 x 3/4" lg.
39	XA-2894-2	1	Shaft, front pivot
40	XB-21-S-375-3000	1	Pin, spring 3/8" x 3"
41	XB-2928	8	Connector, male
42*	XB-338	2	Nut, lock, 3/8"-16
43	XB-2930-A	1	Manifold, hydraulic piping
44a*	XB-08894	2	HHCS, 3/8"-16 x 2-3/4"
44b*	XB-C-38-C-214	2	HHCS, 3/8"-16 x 2-1/4"
45	XB-2936	2	Hose assy
46	XB-2936-1	2	Hose assy
47	XA-2811	2	Clevis S/A
48	XA-0861	4	Bearing
49	XB-H-38	10	Fitting, lube
50	XB-0103	4	Nut, lock, 1/2"-13
51	XB-BR-12-C-4	4	HHCS, 1/2"-13 x 4"
52	XB-767	2	Fitting, lube
53	XA-2893	1	Shaft, axle
54	XA-2809	2	Shaft, pivot
55	XA-2801-AX-1	1	Plate S/A, fifth wheel
56	RK-2774	N/A	Kit rod bearing (XA-2710-1 XA-2810-1)

XA-2801-AX-1 TOP PLATE

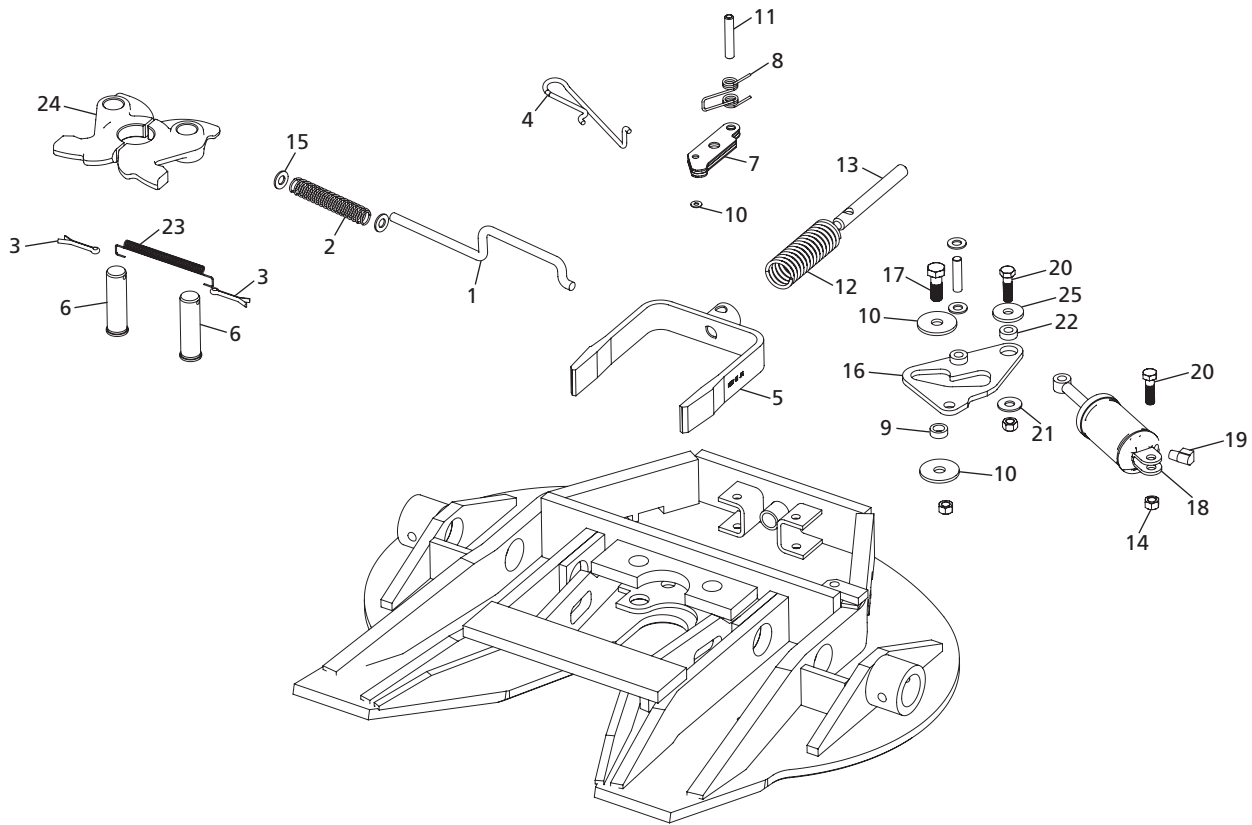

RK-65021-2
Complete Rebuild Kit XA-2801-AX-1

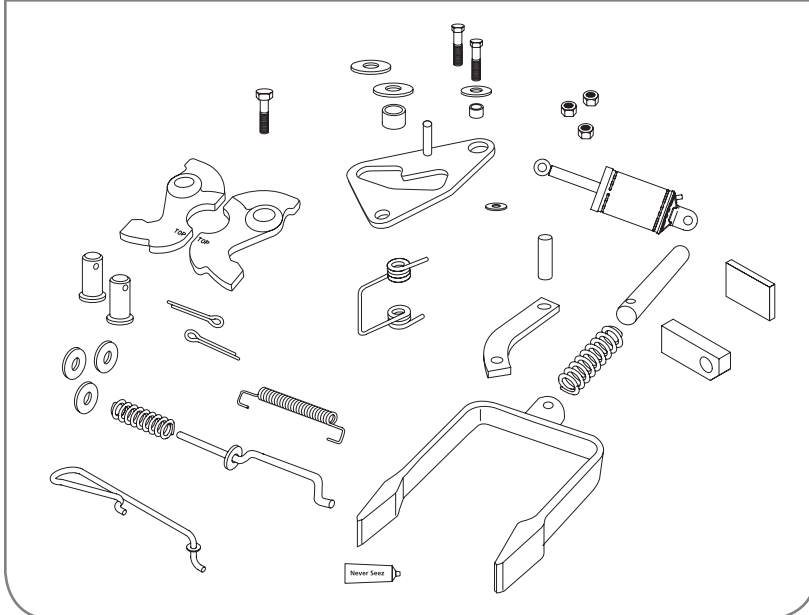

RK-63504
Lock Kit

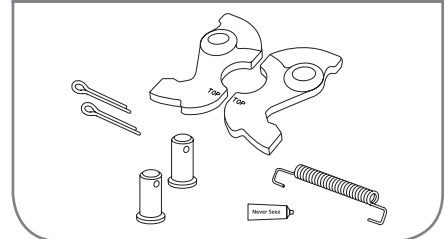

ITEM	PART NO.	QTY	DESCRIPTION
1	XA-1707-16	1	Release handle S/A
2	XB-1028-1	1	Spring
3	XB-5	2	Cotter, 1/4" x 2"
4	XA-3544-1-A	1	Handle S/A (1/4" dia)
5	XA-1703-F	1	Yoke S/A
6	XA-1313	2	Pin, lock
7	XA-3528	1	Bar, lock
8	XB-2149	1	Spring, torsion
9	XA-1507-1	1	Roller,cam
10	XB-1030-1	2	Washer
11	XB-21-S-500-2750	1	Pin, spring 1/2" x 2-3/4"
12	XB-1505	1	Spring
13	XA-1706-1	1	Shaft, yoke
14	XB-T-69-A	3	Nut, lock, 1/2"-20 (Grade C)
15	XB-PW-1732-1-116	3	Washer, 1/2" I.D. x 1" O.D., SAE
16	XA-1705-11	1	Cam S/A
17	XB-CX-58-F-134	1	HHCS, 5/8"-18 x 1-3/4"
18	XA-11694	1	Cylinder S/A, air
19	XB-01996	1	Elbow, 90° Street
20	XB-2083	2	HHCS, 1/2"-20 x 1-3/4"
21	XB-T-49	1	Washer, 1/2"
22	XA-1029	1	Roller
23	XB-GT-13-1	1	Spring, extension
24	XA-1704-X	1	Set, lock jaw
25	XB-10267	1	Washer, 9/16"







From fifth wheel rebuild kits to suspension bushing repair kits, SAF-HOLLAND Original Parts are the same quality components used in the original component assembly.

SAF-HOLLAND Original Parts are tested and designed to provide maximum performance and durability. Will-fits, look-alikes or, worse yet, counterfeit parts will only limit the performance potential and could possibly void SAF-HOLLAND's warranty. Always be sure to spec SAF-HOLLAND Original Parts when servicing your SAF-HOLLAND product.

SAF-HOLLAND USA • 888.396.6501 • Fax 800.356.3929
www.safholland.us

SAF-HOLLAND CANADA • 519.537.3494 • Fax 800.565.7753
WESTERN CANADA • 604.574.7491 • Fax 604.574.0244
www.safholland.ca

SAF-HOLLAND MEXICO • 52.55.5362.8743 • Fax 52.55.5362.8743
www.safholland.com.mx

info@safholland.com