



# RL/RLU SERIES

## PIVOT & AXLE CONNECTION REPLACEMENT INSTRUCTIONS

---

### RL/RLU Series Trailer Suspensions

---

#### Pivot & Axle Connection Replacement Instructions

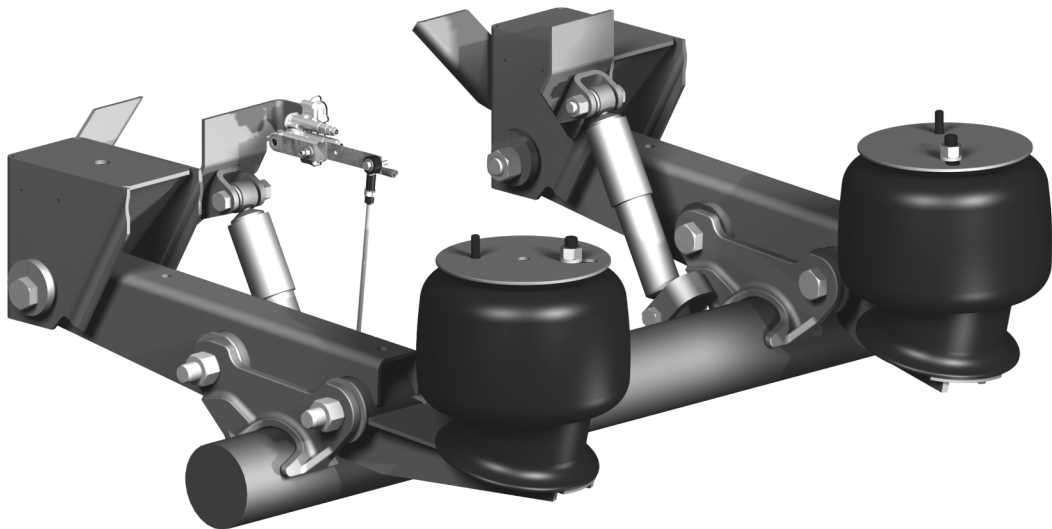

RL SUSPENSION

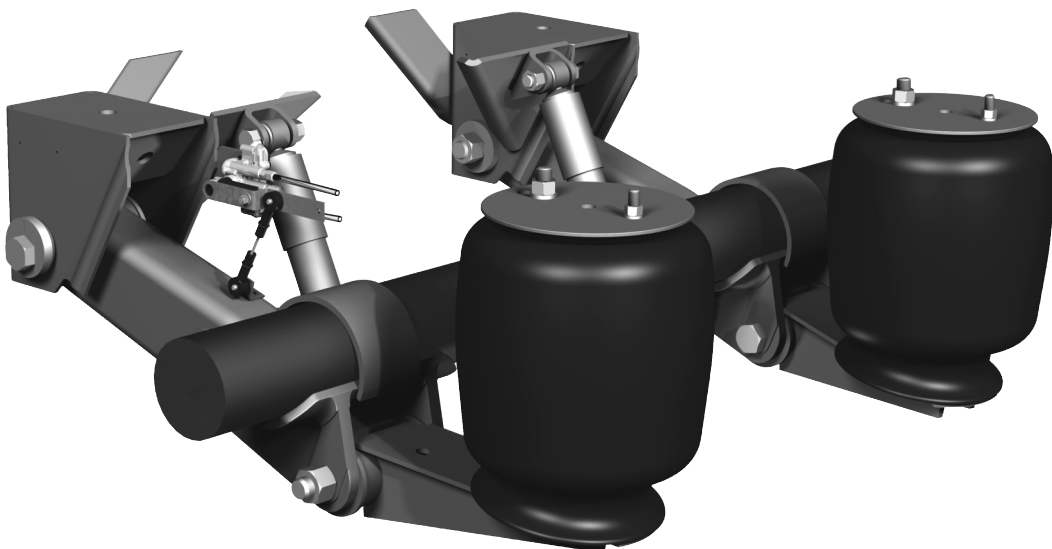

RLU SUSPENSION

# CONTENTS

	Page		Page
Introduction.....	2	Height Control Valve Information .....	6
Warranty .....	2	Torque Specifications .....	7
Notes, Cautions, and Warnings .....	2	Pre-Operational Checklist .....	7 - 8
Component Replacement Instructions .....	3 - 5	Contact Information .....	8
Axle Alignment .....	5		

## INTRODUCTION

This manual provides you information necessary for the pivot and axle connection bushing replacement of SAF-HOLLAND's RL/RLU Series trailer air suspensions.

The SAF-HOLLAND Trailer Air Suspension is designed and engineered to provide trouble-free service.

The suspension also provides excellent side-to-side and axle-to-axle loading which helps equalize and control braking.

## WARRANTY

Refer to the complete warranty for the country in which the product will be used. A copy of the written warranty is on the SAF-HOLLAND Web Site ([www.safholland.us](http://www.safholland.us)).

It may also be ordered directly from the address shown on the back cover.

## NOTES, CAUTIONS, AND WARNINGS

You must read and understand all of the safety procedures presented in this manual before starting any work on the suspension.

Proper tools must be used to perform the maintenance and repair procedures described in this manual. Many of these procedures require special tools.

Failure to use the proper equipment could result in personal injury and/or damage to the suspension.

**Safety glasses must be worn at all times when performing the procedures covered in this manual.**

Throughout this manual, you will notice the terms "NOTE," "IMPORTANT," "CAUTION" and "WARNING" followed by important product information. So that you may better understand the manual, those terms are as follows:

**NOTE:** Includes additional information to enable accurate and easy performance of procedures.

**IMPORTANT:** Includes additional information that if not followed could lead to hindered product performance.

**CAUTION** Used without the safety alert symbol, indicates a potentially hazardous situation which, if not avoided, may result in property damage.

**⚠ CAUTION** Indicates a potentially hazardous situation which, if not avoided, may result in minor or moderate injury.

**⚠ WARNING** Indicates a potentially hazardous situation which, if not avoided, could result in death or serious injury.

# COMPONENT REPLACEMENT INSTRUCTIONS

## Pivot and Axle Connection Rubber Bushings

**IMPORTANT:** When replacing the rubber bushings at these connections be sure the proper SAF-HOLLAND SRK (Service Repair Kit) is used as they contain all necessary parts to service one axle (2 kits per tandem). It may be advantageous to service both pivot and axle connections at the same time.

**NOTE:** The SAF-HOLLAND Bushing Service Tool, Part No. 505 44 012 is available to ease removal and replacement of bushings. Contact your SAF-HOLLAND distributor or Parts List for details.

**FIGURE 1**  
Bushing Service Tool

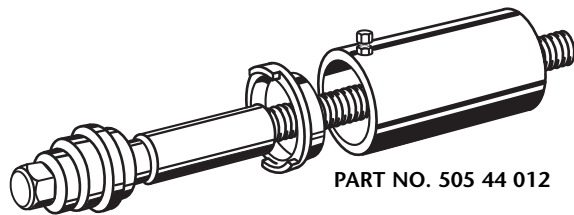

**IMPORTANT:** It is recommended that the vehicle be unloaded before beginning service procedures.

1. Support vehicle frame with adequate jack stands. Set jack stand height at approximately 2" (51mm) above the suspension's specified ride height.

**WARNING** Failure to properly support suspension during maintenance may allow suspension to fall which, if not avoided, could result in death or serious injury.

**NOTE:** The height control valve may be used as an improvised jack by disconnecting the lower height control valve (HCV) linkage and moving the HCV control arm to "up" position to raise vehicle (FIGURE 9 on page 6). With vehicle raised above the height specified in step 1, position jack stands under vehicle frame at OEM specified locations and move control arm to "down" position to lower vehicle onto jack stands. Hold control arm down until air springs are completely exhausted.

**CAUTION** Exhaust all air pressure from the system or personal injury may occur.

2. Exhaust air from the suspension system by:
  - Automatic control — use height control valve by disconnecting link at lower connection, then rotate control arm to exhaust (approx. 45° down) position, or
  - Disconnect air supply line from air spring.
3. If servicing all equalizing beam bushings, equalizing beam must be completely removed.

**NOTE:** If servicing the front pivot bushing only and using the SAF-HOLLAND Bushing Service Tool, remove the pivot bolts and rotate front of equalizing beams downward to gain access to bushing.

4. Disconnect air spring, shock absorber and height control valve linkage at lower connections.
5. Disconnect front pivot and axle connection hardware then remove equalizing beam (FIGURE 2).

**FIGURE 2**  
Pivot and Axle Connections

### RL Series

#### EZ-ALIGN PIVOT CONNECTION

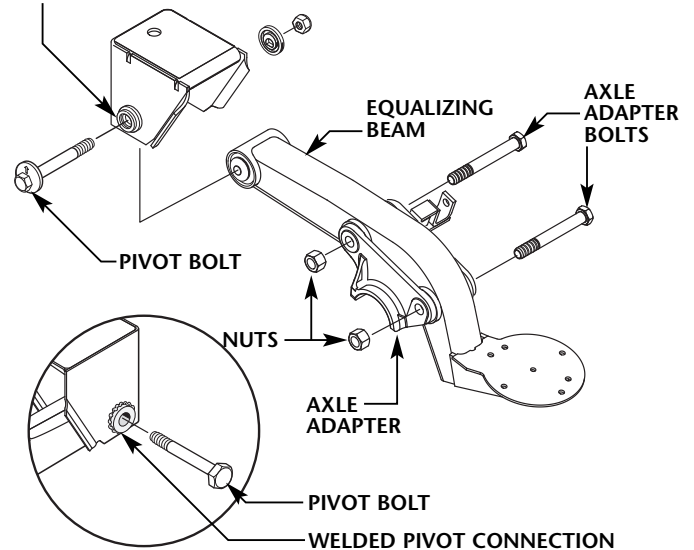

### RLU Series

#### EZ-ALIGN PIVOT CONNECTION

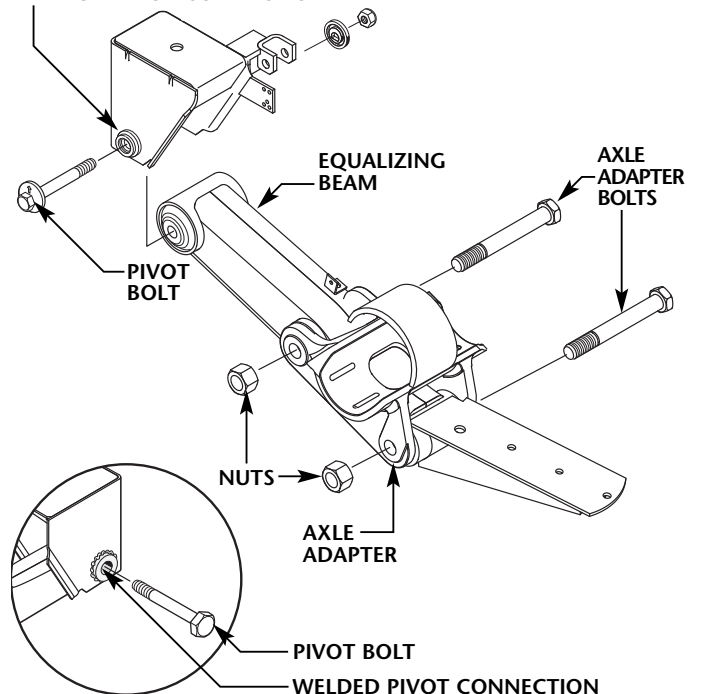

# COMPONENT REPLACEMENT INSTRUCTIONS *continued*

## Pivot and Axle Connection Rubber Bushings *continued*

- Inspect axle adapters for wear, cracks and failed welds. Axle adapters should have a 1/2" (13mm) (3 pass) fillet weld (refer to proper Holland welding specifications). Replace all worn or cracked axle adapters.
- Inspect equalizing beams for wear, cracks and failed welds. Replace cracked equalizing beams.

**IMPORTANT:** NEVER repair a cracked equalizing beam. DO NOT weld cracks. Secondary weld failures during use may cause loss of vehicle control.

**WARNING** Failure to replace a cracked equalizing beam may cause loss of vehicle control which, if not avoided, could result in death or serious injury.

- Press out old bushing(s) using a SAF-HOLLAND Bushing Service Tool, Part No. 505 44 012.

**IMPORTANT:** DO NOT use an open flame or other heat source to remove the bushings.

- Clean out all foreign material from bushing receptacle(s). Lubricate new bushing(s) with approved lubricant, or a soap and water solution.

**IMPORTANT:** DO NOT use oil-based lubricant or brake fluid, as it can cause damage to the rubber.

**NOTE:** Service wear washers 900 36 175 (FIGURE 5A) may be required on pre 1990 model AR-90 suspension. If the Equalizing Beam tubes show excessive wear, grind the tube flat to 3/16" from the side of the beam.

**FIGURE 3**  
Equalizing Beam Bushings Location

### RL Series

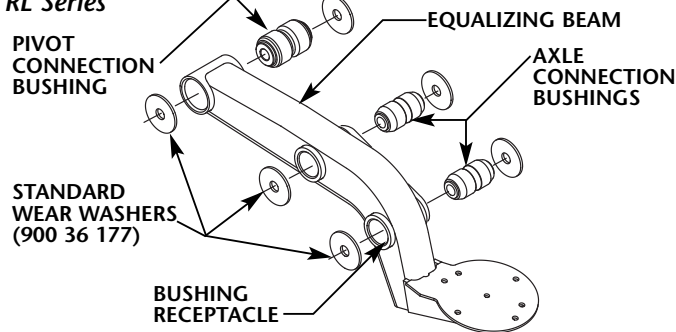

### RLU Series

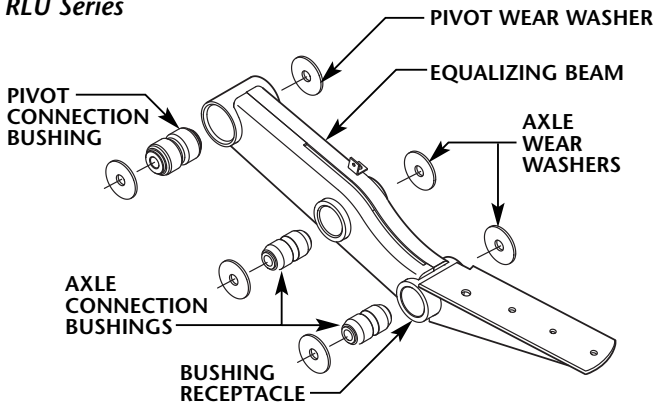

**FIGURE 4**  
Centering Bushings in Equalizing Beam

### Top View of Beam

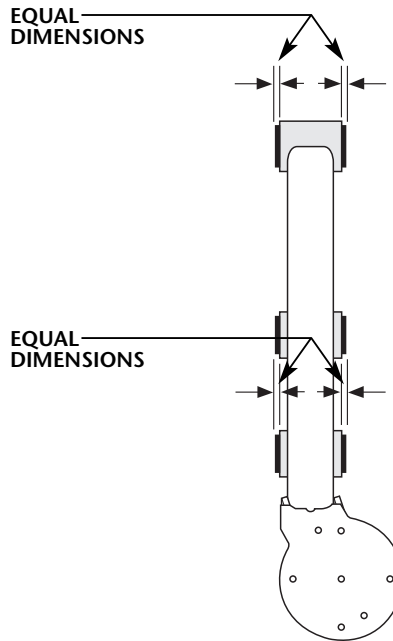

**FIGURE 5**  
Wear Washer Locations

### Pivot Connection

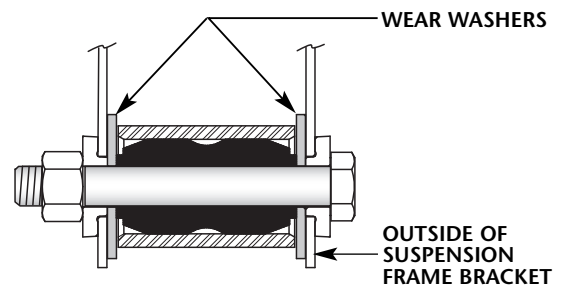

**FIGURE 5A**  
Wear Washer Locations

### Axle Connection

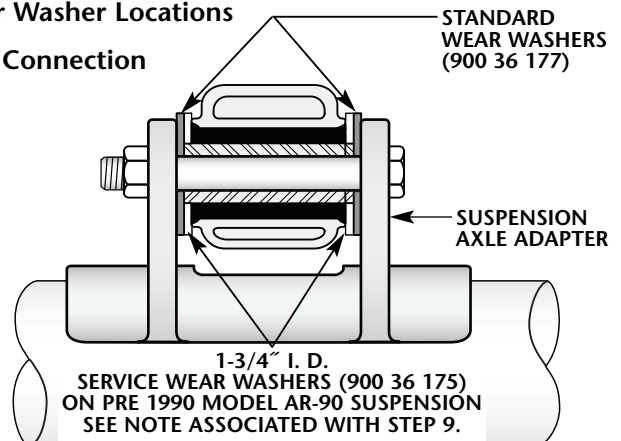

## COMPONENT REPLACEMENT INSTRUCTIONS *continued*

- Press new bushing(s) in beam. Bushing(s) must be centered in beam receptacles. It may be necessary to push bushing past center approximately 1" (25.4mm) and then re-center the bushing to relieve the rubber (**FIGURES 3 and 4**).
- Re-install equalizing beam with new wear washers, bolts and nuts. Be sure to install wear washers in proper locations (**FIGURE 5**). Position at ride height and properly torque fasteners (see *Torque Charts* on page 7).
- Reconnect air springs, shock absorbers and height control valve linkage. Properly torque fasteners (see *Torque Chart* on page 7).
- Remove jack stands. Build system air pressure in excess of 75 psig (5.2 bars) and check for leaks in air system at all connections.

**IMPORTANT:** It is the responsibility of the air system installer to secure all air lines and check for any air leaks. If air leaks are detected, repair as required. Failure to eliminate the air leaks may compromise the suspension performance.

## AXLE ALIGNMENT

**IMPORTANT:** Axle alignment can only be achieved if the frame bracket pivot holes are evenly located from the kingpin, left and right. Axle alignment should always be done while the trailer is empty.

- To properly align the suspension, the trailer should be pulled in a straight line for a sufficient distance to insure there are no binds in the suspension.
- Alignment can be achieved with an optical device designed especially for this purpose or manually by the following manner: Measure the distance from the king pin to the center line of the spindles on the front axles. It is recommended that spindle extensions be utilized. Dimensions A and B must be equal within 1/8" (3mm). Dimension E is equal to the distance between the trailer center line and the axle center line (**FIGURE 6**).

**FIGURE 6**  
Slider Suspension Alignment

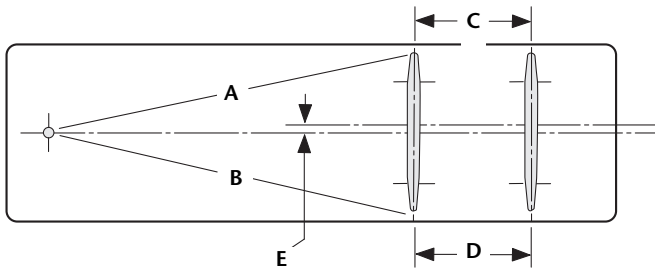

- A = B ± 1/8" (3mm)  
 C = D ± 1/16" (1.6mm)  
 E = ≤ 1/16" (1.6mm)

### **EZ-Align (Non-welded) Connection Axle Alignment**

- Loosen the 1/8" pivot bolt connection nut (**FIGURE 7**).

**IMPORTANT:** DO NOT remove weld from bolt head.

- Rotate bolt head clockwise to move axle forward (A arrows); counterclockwise to move axle rearward (B arrows) (**FIGURE 7**).
- Retorque the pivot bolt connection nut, no weld required (see **FIGURE 10** on page 7). See **TABLE 2 Pivot Bolt Torque Chart** on page 7.

**IMPORTANT:** DO NOT weld EZ-Align pivot bolt (alignment block) assembly to alignment collars on frame brackets (**FIGURE 8**).

**FIGURE 7**  
EZ-Align

Alignment arrow indicates (neutral position of) alignment adjustment

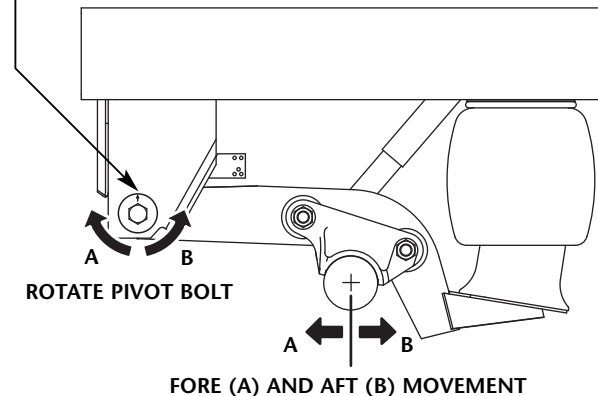

**FIGURE 8**  
EZ-Align Non-Welded Style Assembly

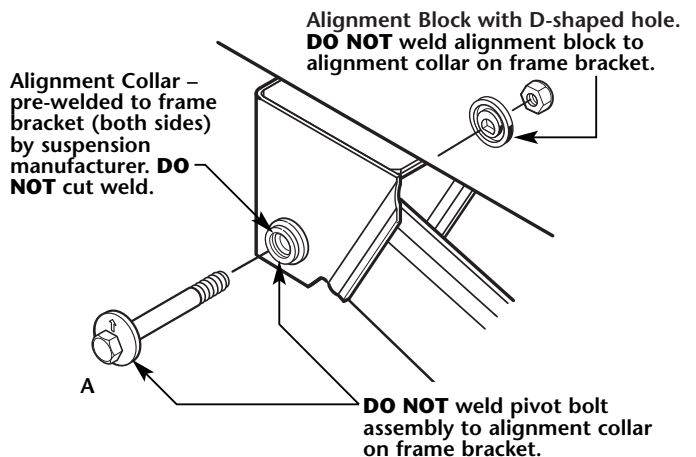

**IMPORTANT:** The EZ-Align design maintains proper alignment under correct torque without welding.

# HEIGHT CONTROL VALVE INFORMATION

## Height Control Valve Inspection

**IMPORTANT:** DO NOT grease height control valve.

1. Visually inspect the valve and linkage on a regular basis for proper clearance, operation and adjustment.
2. Dirt or foreign particles in the air line may harm the internal workings of the valve. Even though it contains a protective filter to eliminate foreign matter, normal air brake system maintenance should be practiced.
3. Drain moisture from air tank periodically. In severe cold weather an air dryer and/or an alcohol evaporator is recommended to avoid valve freezing and damage.

## Height Control Valve Performance Check

**IMPORTANT:** Proper inspection can eliminate unnecessary replacement of height control valve.

1. Apply air system pressure in excess of 75 psig (5.2 bars).
2. Disconnect lower connection of the link assembly from mounting bracket.
3. Move control arm up to 45° for 10-15 seconds - air should flow to air spring(s) (**FIGURE 9**).
4. Move control arm to center (neutral) position - valve should shut off air flow.
5. Move control arm down 45° for 10-15 seconds - air should exhaust.
6. Move control arm to center (neutral) position - valve should shut off air flow.
7. Valve is good if performance is as noted.

**NOTE:** If the valve does not perform correctly, contact SAF-HOLLAND Technical Service: 888-396-6501.

8. Reconnect lower link assembly to mounting bracket and torque to 30-40 in. lbs. (3.75-5 Nm).

**FIGURE 9**  
Height Control Valve Performance Check

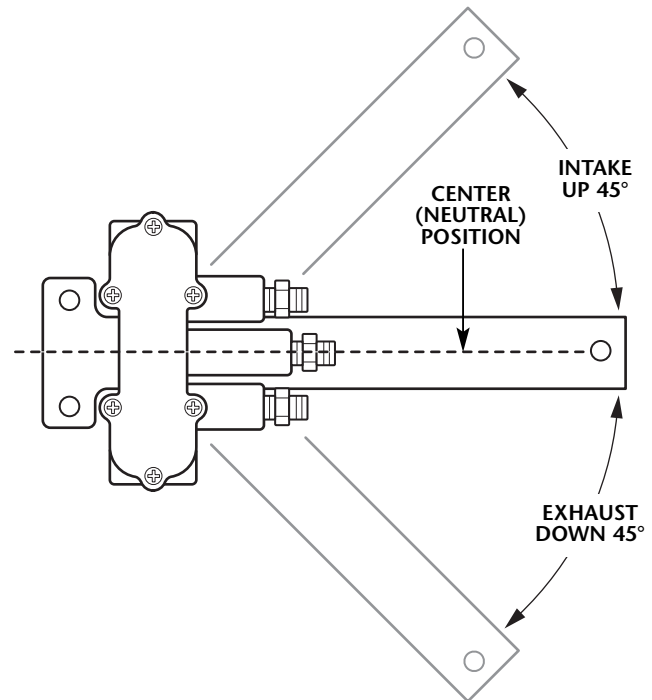

**IMPORTANT:** If 75 psig (5.2 bars) air system pressure cannot be achieved, check pressure protection valve and vehicle air compressor to see if they are operating properly. Also check the air lines for obstructions caused by dirt particles, foreign debris, ice, etc.

# PRE-OPERATIONAL CHECKLIST

**TABLE 1**  
**Torque Chart**

SIZE	TORQUE FT. LBS.	TORQUE NM
3/4"	150	203
1 1/8" (Axle Conn.)	800	1083
1 1/8" (Pivot Conn.)	See Table 2	
1/2" - Air Spring	30 - 40	41 - 54
3/4" - Air Spring	40 - 45	54 - 61

BOLT SIZE	SOCKET SIZE
1/2"	3/4"
3/4"	1 1/8"
1 1/8"	1 11/16"*

\*Deep Well Socket

**IMPORTANT:** Torque requirements listed are for clean and lubricated threads.

Use of special lubricants with friction modifiers, such as Anti-Seize or Never-Seize, without written approval from SAF-HOLLAND Engineering will void warranty and could lead to premature bolt failure or other component issues.

**TABLE 2**  
**Pivot Bolt Torque Chart**

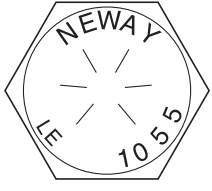
IDENTIFIER	NEW PIVOT BOLT	OLD PIVOT BOLT
Bolt Head Marking		
Color	Silver	Black
Surface Appearance	Dry	Wet - Oily
Torque Specification	<b>550 FT. LBS.</b> (745 Nm)	<b>800 FT. LBS.</b> (1083 Nm)

**WARNING** DO NOT torque **old** pivot bolt to the new torque specification of 550 ft. lbs. (745 Nm). Pivot may loosen causing premature wear or fracturing of the bolt and other suspension components that could result in a loss of vehicle control.

**CAUTION** DO NOT torque **new** pivot bolt to the old torque specification of 800 ft. lbs. (1083 Nm). Removal or loosening of pivot bolt for service, repair, or axle alignment may become difficult if the new bolt is torqued to 800 ft. lbs. (1083 Nm).

**FIGURE 10**  
**EZ-Align (Non-welded) Axle Alignment**

**NON-WELDED STYLE SIDE VIEW**

**IMPORTANT:** The EZ-Align design maintains proper alignment under correct torque without welding. See page 5 for "EZ-Align (Non-welded) Connection Axle Alignment" procedure.

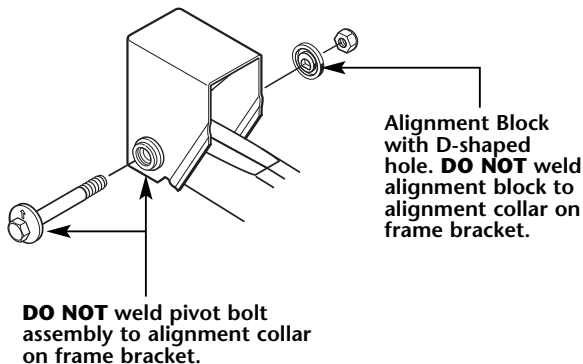
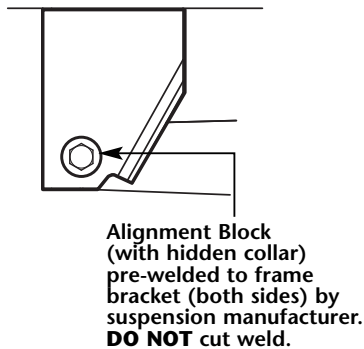

**FIGURE 11**  
**Welded Adjustable Axle Alignment**

**WELDED STYLE SIDE VIEW**

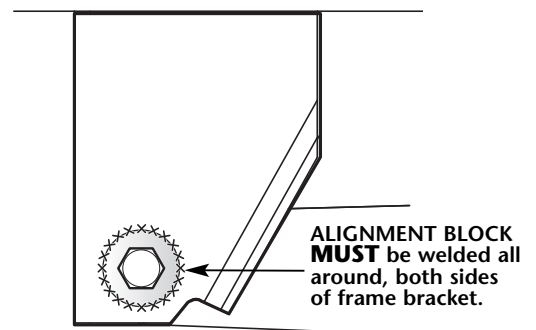

# PRE-OPERATIONAL CHECKLIST continued

**Prior to placing unit in service, check the following items:**

**⚠ WARNING** Failure to chock tires prior to beginning maintenance could allow vehicle rollaway which, if not avoided, could result in death or serious injury.

1. Build air pressure above 75 psig (5.2 bars). With the vehicle shut off, check the system for air leaks.

**IMPORTANT:** It is the responsibility of the air system installer to secure all air lines and check for any air leaks. If air leaks are detected, repair as required. Failure to eliminate the air leaks may compromise the suspension performance.

2. With the vehicle on a level surface and air supply pressure in excess of 75 psig (5.2 bars), check the air springs for equal firmness.
3. Check the shock absorbers for proper installation. The 3/4" shock absorber nuts must be torqued to specifications (see **TABLE 1 Torque Chart** on page 7).
4. The 1/2" and 3/4" air spring mounting nuts must be torqued to specifications (see **TABLE 1 Torque Chart** on page 7).
5. Check for 1" (25mm) minimum clearance around the air springs with vehicle loaded (**FIGURE 12**).
6. The 1/8" axle connection nuts must be torqued to specifications (see **TABLE 1 Torque Chart** on page 7).

7. The suspension ride height should be within  $\pm 1/8"$  of the recommended design height.
8. Visually check the welding of all axle adapters to axles — 1/2" (13mm) minimum fillet weld required (**FIGURE 12**).
9. Visually check the welding of all curbside fixed alignment pivot connections on both sides of frame bracket (**FIGURE 11**).

If welds are not present, weld the alignment plates in-board and out-board of the frame bracket per SAF-HOLLAND NS-65-07-CI specification—consult publication XL-AR353-01— and as shown in **FIGURE 11**. Weld all around with 5/16" (8mm) weld.

**IMPORTANT:** The EZ-Align design maintains proper alignment under correct torque without welding; **DO NOT** weld alignment blocks (**FIGURE 10**).

**NOTE:** EZ-Align pivot connections (non-welded) are on roadside and fixed alignment pivot connections (welded) are on curbside. However, some manufacturers use EZ-Align on both sides. See page 5 for "EZ-Align (Non-welded) Connection Axle Alignment" procedure.

10. A 1/8" pivot nut must be torqued to specifications (see **TABLE 2 Pivot Bolt Torque Chart** on page 7).

**FIGURE 12**  
Suspension Pre-Operational Checklist Items

**RL Series**

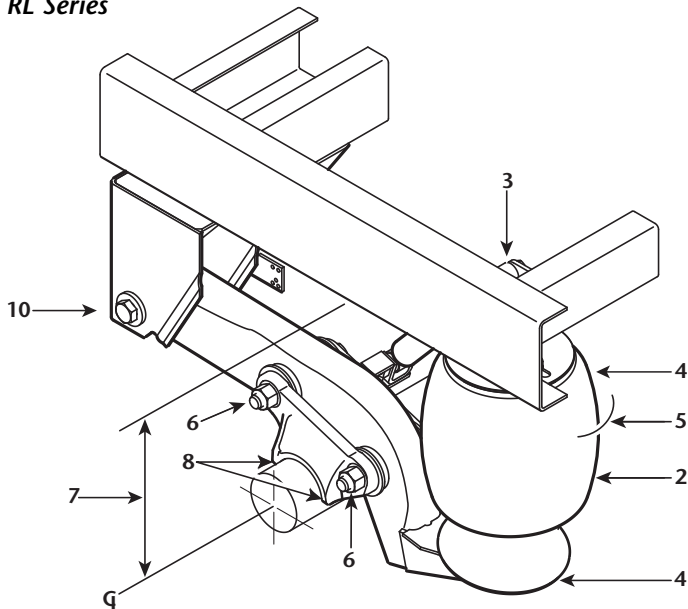

**RLU Series**

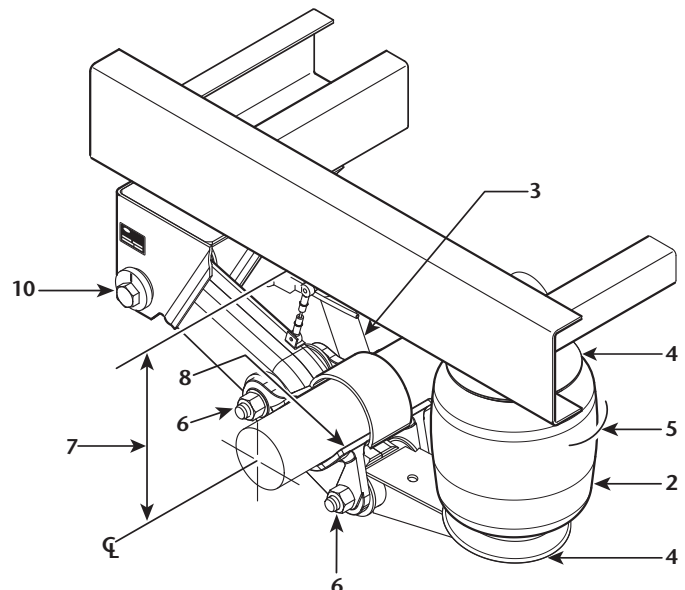

SAF-HOLLAND USA, Inc.  
888.396.6501 Fax 800.356.3929

SAF-HOLLAND Canada Limited  
519.537.3494 Fax 800.565.7753  
Western Canada  
604.574.7491 Fax 604.574.0244