



FIFTH WHEELS

REBUILDING PROCEDURES



XA-3501 Series Fifth Wheel Top Plates

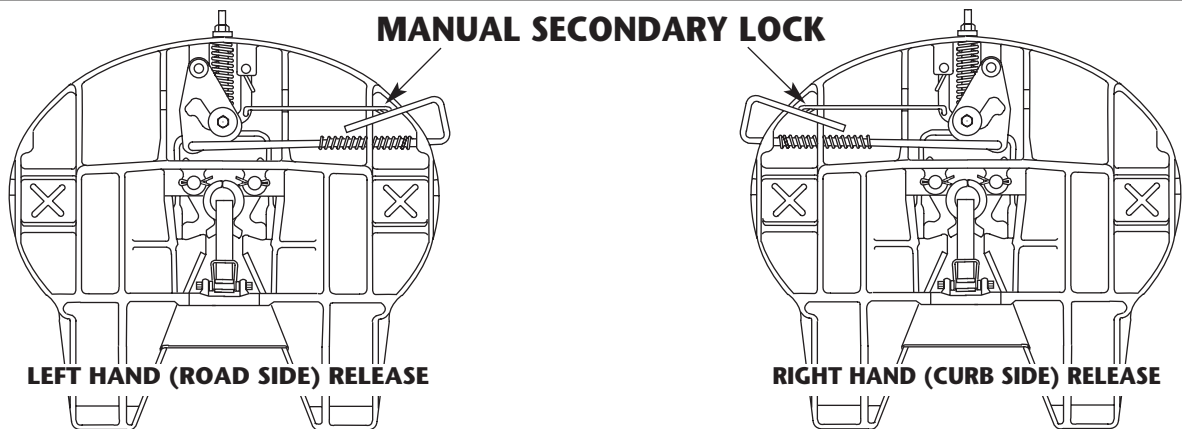

REBUILD KIT NUMBERS

- RK-63501 (STANDARD)
- RK-63506 (Models with Manual Secondary Lock)
- RK-63509 (Lock Pin Bushings)
- RK-63510 (Lock Pin Bushings & Manual Secondary Lock)

- RK-63500 (STANDARD)
- RK-63505 (Models with Manual Secondary Lock)
- RK-63508 (Lock Pin Bushings)
- RK-63511 (Lock Pin Bushings & Manual Secondary Lock)

TROUBLE SHOOTING HINTS

FIFTH WHEEL IS HARD TO HOOK UP TO TRAILER

✓ POSSIBLE CAUSE	REMEDY
<input type="checkbox"/> The trailer may be too high; the kingpin is not entering the locks properly.	Lower the trailer landing gear until bolster plate contacts fifth wheel.
<input type="checkbox"/> Locks are closed.	Pull release handle and pry open locks.
<input type="checkbox"/> Accumulated rust or grime interfering with lock operation.	Spray a light lubricant or diesel fuel on all moving parts including the release handle and operate several times.
<input type="checkbox"/> Bent release handle or kingpin or damaged bolster plate may be interfering with lock movement.	Check and replace as required.
<input type="checkbox"/> The locks may be damaged.	Inspect and replace, if required, following the procedures in this manual.
<input type="checkbox"/> The fifth wheel may need rebuilding.	Follow the procedures contained in this manual using the appropriate rebuilding kit.

FIFTH WHEEL IS HARD TO UNHOOK FROM TRAILER

✓ POSSIBLE CAUSE	REMEDY
<input type="checkbox"/> The secondary lock is not released.	If manual secondary - pull release handle and lock open by resting against the top plate. If automatic secondary - inspect for missing or broken parts and repair or replace as required.
<input type="checkbox"/> The tractor may be putting pressure against locks.	Back the tractor into the trailer to relieve pressure. Lock the tractor brakes. Pull release handle.
<input type="checkbox"/> Rust or grime on locking mechanism.	Spray a light lubricant or diesel fuel on all moving parts including release handle and operate several times.
<input type="checkbox"/> Bent kingpin or damaged bolster plate.	Check the kingpin with a Holland TF-0110 Kingpin Gage and bolster plate with a 48" straight edge - repair or replace as required.
<input type="checkbox"/> Fifth wheel locks may be adjusted to tight.	Check lock adjustment in accordance with the procedures in this manual.
<input type="checkbox"/> Release handle will not stay out or must be held out when unlocking.	Replace the cam and release handle spring. Follow the procedures contained in this manual.

REBUILDING PROCEDURES

1. Before attempting to rebuild, review each trouble shooting hint (front page of this manual). You may find that rebuilding is not necessary.
2. If rebuilding is required, check the front page of this manual to be sure you have the correct kit for the fifth wheel you are about to rebuild.
3. Before proceeding, carefully read the general information contained on the back cover.
4. Close the locks.
5. Totally disassemble and clean the top plate.
6. Inspect the top plate for cracks and loose pin holes. If the plate is cracked, it must be discarded. If the lock pin holes are elongated, the top plate can be returned for a factory rebuilding.



WARNING

Do not attempt repair or rebuilding if the top plate is cracked or distorted or the lock pins (ITEM 2) do not fit tightly as the top plate may fail or the locks may malfunction.

NOTE: When rebuilding, use only Holland rebuilding kits and replace all roll pins, cotter pins, springs, bolts, nuts and washers.

LOCK INSTALLATION

1. Before installing the lock jaws (ITEM 1), lubricate the lock pin holes (A) with *Never Seez*. **DO NOT SUBSTITUTE.**
2. Place the lock jaws into the top plate with the $2\frac{7}{8}$ " bore directed toward the face of the top plate (see Figure 1).
3. Orient the holes in the lock pins (ITEM 2) as shown in Figure 2 (for cotter pin insertion) and drive lock



Figure 1

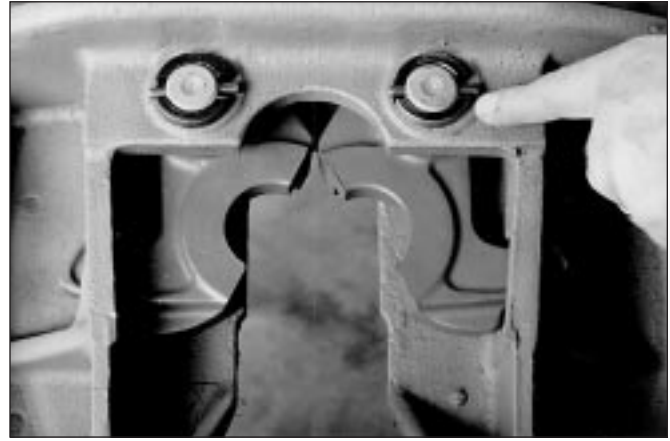

Figure 2

- pins through the top plate and pin holes (A) in lock jaws until the head of the pins are flush with the top plate.
4. Secure the lock pins with cotter pins (ITEM 3).
 5. If top plate is equipped with lock pin bushings (ITEMS 30 & 31), roll pins (ITEM 32) must be used in place of cotter pins (see Figure 2).
 6. Check for free movement of the lock jaws.
 7. Install a 2" diameter plug (Part No. TF-0237 lock gage, available from your Holland distributor) in the lock jaws (see Figure 3).



WARNING

Use either Holland Part No. TF-0237 or a precision plug that is $2.000" \pm .005"$ for proper adjustment of locking mechanism.



Figure 3

YOKE INSTALLATION

NOTE: This is the most critical operation in the rebuild procedure. A precise fit is required for maximum service life.

1. Strike the yoke with a mallet to slightly bend the yoke tips outward (*see Figure 4*).
2. With the 2" diameter plug (TF-0237 lock gage) inserted in the locks, slide the yoke into the top plate with the threaded hole facing up and tap into position.
3. Inspect the yoke tips. They must be flush with the ends of the locks or must not extend more than 1/32" beyond the ends of the locks (*see Figure 5*). If the yoke tips fall short, (*see Figure 6*), it is necessary to grind the outside surfaces of the yoke until it fits precisely into place. Use a belt sander or disc grinder for this operation (*see Figure 7*).



Figure 4



Figure 5



Figure 6



WARNING

Never grind on the inside of the yoke or on the locks.

If the yoke tips extend beyond, it is necessary to build up the outer surfaces of the yoke using a low hydrogen E70XX welding rod (*see Figure 8*). After welding, grind the beads smooth. **NOTE:** Immediately after welding or grinding, dip the yoke tips into water to quench.

4. After welding and grinding, be sure that the yoke surface has full area contact with the top plate rib. This contact must be at the ends as well as extend along the length of the yoke tip (*see Figure 9*).



Figure 7



Figure 8

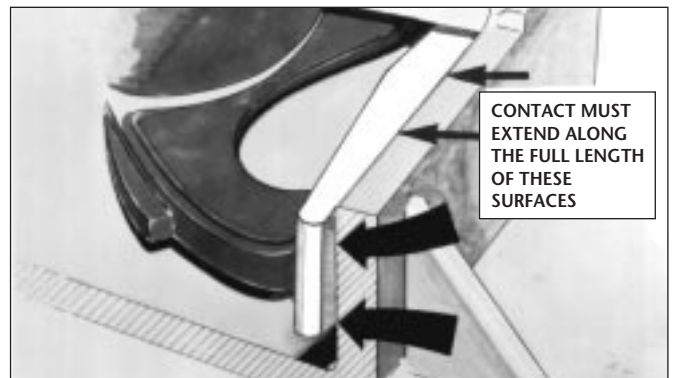

Figure 9

5. Continue the weld, grind and fit process until the yoke has full contact and the yoke tips are flush with the ends of the locks.
6. Lube both the inside and outside friction surfaces of the yoke and then slide into the top plate with the threaded hole facing up.
7. Install spring (*Item 5*) between yoke and top plate. Insert the yoke shank (*Item 6*) through the top plate, spring, and into the yoke. Make sure that the pre-drilled recess in the yoke shank aligns with the threaded hole in the yoke.
8. Finally, in this order, install the lock adjustment tag, the rubber washer, a 13/16" I.D. steel washer and the 3/4" lock nut.

RELEASE MECHANISM INSTALLATION

RIGHT HAND (CURB SIDE) RELEASE

1. Install a 9/16" I.D. washer (*Item 11*) on the release handle as shown in the exploded view.
2. Pass the open end of the release handle through guide hole (B) towards the outside of the top plate.
3. Inspect the cam plate (*Item 13*) for burrs or rough edges in the cam profile. Remove as required.
4. Lube the cam profile and pivot holes with a light grease.
5. Insert the "S" end of the release handle through the small hole in the cam.
6. Lay the cam on the top plate (*see Figure 10*) so that the cam profile is over the hole in the yoke and the large hole is over the lug in the top plate opposite the release handle.
7. Slide a 9/16" I.D. flat washer between the top plate lug and cam with the rounded edge towards the cam (*see Figure 10*).



Figure 10

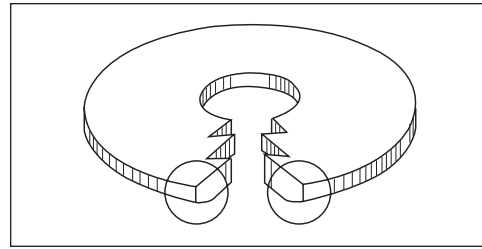

Figure 10A

Important: When assembling washers to the cam, be certain that the rounded edge always faces the cam (*see Figure 10A*).

8. Next, install the 1/2" I.D. roller (*Item 14*) in the large hole of the cam.
9. Lay a second 9/16" I.D. flat washer over the cam. Make certain that the rounded edge of the washer faces the cam.
10. Install the 1/2" diameter bolt through the washers, roller and top plate lug.
11. Secure the bolt with a 1/2" lock nut. Tighten securely, then check for free movement of the cam.

LEFT HAND (ROAD SIDE) RELEASE

Complete procedures 1-11 above, except:

1. Pass the open end of the release handle through guide hole (C) towards the outside of the top plate.
2. The cam plate must be flipped over and the large hole must be over the other top plate lug.

PREPARE YOKE FOR ACTUATION

1. Place a 5/8" I.D. flat washer (*Item 17*) between the yoke and cam. Again, be sure the rounded edge faces the cam.
2. Insert the 5/8" I.D. roller (*Item 18*) in the cam opening.
3. Install the second 5/8" I.D. flat washer (*Item 17*) on top of the cam.
4. Pass the 5/8" diameter bolt (*Item 19*) through the assembly. Be certain that the bolt passes through the yoke and into the recess in the yoke shank.
5. Tighten securely, but make sure the top washer (*Item 17*) rotates freely.
6. After completing the above procedures, turn the nut on the yoke shank clockwise until you can just turn the rubber washer (*Item 8*) on the yoke shank. The locking mechanism is now properly adjusted.
7. Pull the release handle and remove the plug (Holland Part No. TF-0237).

SECONDARY LOCK ASSEMBLY

AUTOMATIC VERSION

1. Start the roll pin into the hole in the top plate lug opposite the cam anchor bolt.
2. Assemble the secondary lock to the torsion spring (*ITEM 21*) and place them into position. Be sure that the open end of the spring faces toward the rib of the lug (*see Figure 11*).



Figure 11

3. With the parts in position, drive the roll pin until it is flush with the lug.
4. Finally, check the secondary lock for spring tension and free movement.

MANUAL VERSION

1. Pass the end of the manual secondary lock handle (*ITEM 28*) through hole (D) for curb side or hole (E) for road side.
2. Attach the handle to the secondary lock (*ITEM 29*) by inserting the "S" end of the handle into hole (F).
3. Complete procedures **1** through **4** above ("Automated Version").

LOCK GUARD INSTALLATION

1. Pull the release handle, remove the plug and pry open the lock jaws.
2. Assemble the lock guard (*ITEM 23*) and torsion spring (*ITEM 24*).
3. Mount the lock guard into place using the pivot shaft and cotter pins (*see Figure 12*).
4. Check the lock guard for spring tension and free movement.
5. Check the adjustment. When properly adjusted, the tip of the lock guard should be even with the edge of the 2-inch bore in the lock jaws (*see Figure 13*).



Figure 12

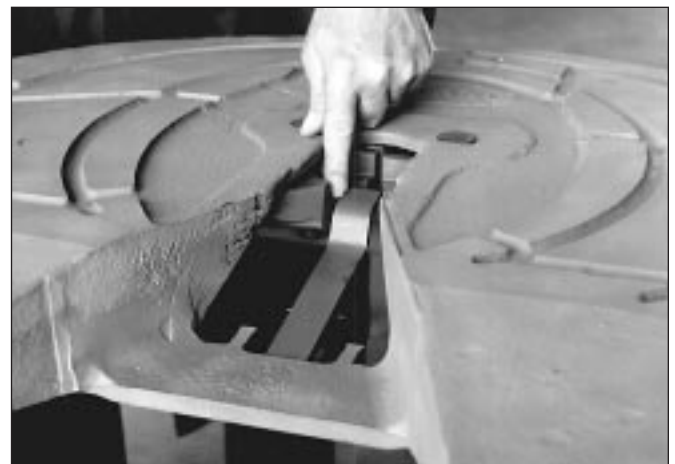

Figure 13

6. Adjust the position of the lock guard by supporting the end of the guard with a short piece of steel placed between the locks and lock guard and then tap the center of the guard to adjust (*see Figure 14*).



Figure 14

CHECK FIFTH WHEEL OPERATION

As a final check of the rebuild, close the locks using a Holland Lock Tester. Verify that the locking mechanism functions properly (*see Figure 15*).

NOTE: Refer to Holland Publication XL-FW340 for specific details on how to operate the tester.



Figure 15



If the fifth wheel does not operate properly, **DO NOT USE IT**. Either disassemble and repeat rebuilding procedures, or contact your local Holland representative for assistance. Never use a fifth wheel that does not operate properly.

PERIODIC MAINTENANCE ADJUSTMENT

For maximum service life, the fifth wheel should be checked and adjusted as necessary every 30,000 miles or as part of regular scheduled inspections. To do this, proceed as follows:

1. Close the locks and insert the plug (Holland Part No. TF-0237) in the locks.
2. Check for a tight fit. The plug should be snug, but you should be able to rotate it by applying some force.
3. If the plug fits loosely, tighten by rotating the nut on the shank counterclockwise. It may be necessary to tap the end of the yoke shank lightly to allow the nut to seat against the top plate.
4. Repeat this procedure until the plug fits snug but can still be rotated. The locks are now properly adjusted.
5. Verify the proper operation of the locking mechanism using the lock tester. (See "Check Fifth Wheel Operation," above).

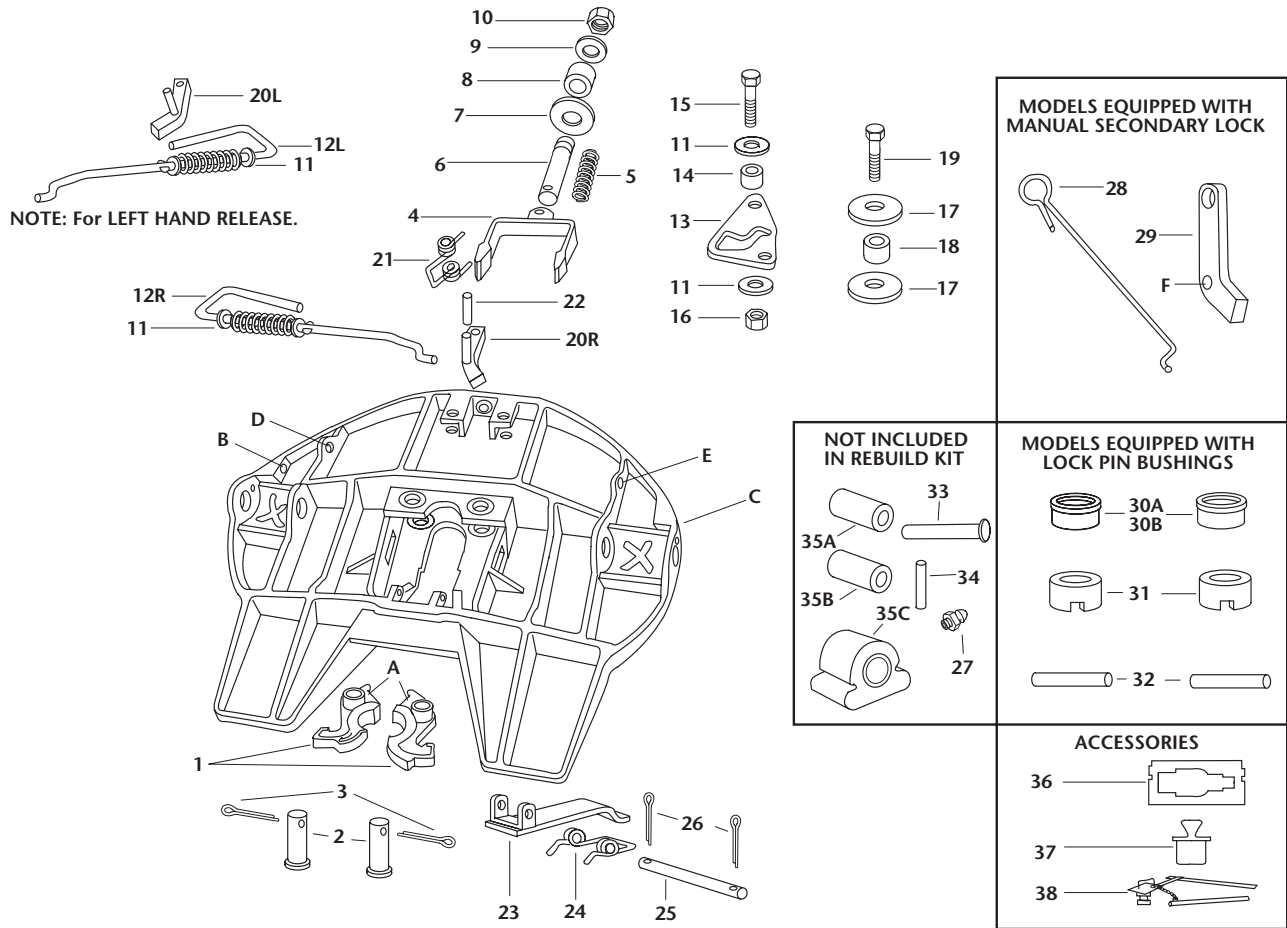

ITEM	PART NO.	NO. REQ'D	PART NAME	ITEM	PART NO.	NO. REQ'D	PART NAME
1	XA-1704	1	Lock jaws	21	XB-2149	1	Torsion spring
2	XA-1313	2	Lock pin	22	XB-21-S-500-2750	1	Roll pin
3	XB-5	2	Cotter pin 1/4" x 2"	23	XA-3514	1	Lock guard
4	XA-1703-F	1	Yoke sub-assy.	24	XB-1044	1	Torsion spring
5	XB-1505	1	Spring	25	XA-1055	1	Pin
6	XA-1706	1	Yoke shaft	26	XB-16	2	Cotter pin 1/8" x 1"
7	XB-02312	1	Lock adjustment tag	†27	XB-H-38	2	Grease fitting
8	XB-1127	1	Rubber washer	*28	XA-3542-M	1	Manual secondary lock handle
9	XB-PW-1316-112	1	Washer 1½" O.D. x 13/16" I.D.	*29	XA-3528	1	Manual secondary lock
10	XB-HNH-34-F	1	Locknut 3/4"-16	**30	XA-01241	2	Lock pin bushing
11	XB-T-49	3	Washer 1¾" O.D. x 9/16" I.D.	**31	XA-01242	2	Lock pin bushing
12L	RK-1707-M	1	Left hand release handle sub-assy. (Part No. (11) must be installed on handle for complete assembly.)	**32	XB-21-S-250-1875	2	Roll pin - MUST be used with part nos. (2) when wheel is equipped with lock pin bushings
12R	RK-1707-6	1	Right hand release handle sub-assy. (Part No. (11) must be installed on handle for complete assembly.)	†33	XA-2016	2	Bracket pin
13	XA-1705	1	Cam plate	†34	XB-21-S-375-1750	2	Roll pin
14	XA-1029	1	Roller	†35A	XB-1604-5	2	Rubber bushings (for fifth wheels m'f'd. prior to 5/82)
15	XB-2083	1	Bolt 1/2"-10 x 1¾"	†35B	XB-0011-1	2	Rub. bush. (no longer available order XA-0011-2 and see Service Bulletin XL-SB16 for instructions)
16	XB-T-69-A	1	Locknut 1/2"-20	†35C	XB-0011-2	2	Rubber bushings (for fifth wheels m'f'd. after 6/87)
17	XB-1030-1	2	Washer	†36	TF-0110	1	Kingpin gage
18	XA-1507	1	Roller	†37	TF-0237	1	2" Lock gage
19	XB-CX-58-F-134	1	Bolt 5/8"-18 x 1¾"	†38	TF-TLN-1000	1	Kingpin lock tester
20L	XA-3542-L	1	Secondary lock, left hand				
20R	XA-3542-R	1	Secondary lock, right hand				

* Additional parts included in RK-63505, RK-63506, RK-63510 or RK-63511 rebuild kits.

** Additional parts included in RK-63508, RK-63510, RK-63511 rebuild kits.

† Not included in rebuild kits.

ACCESSORIES: TF-TLN-1000 2" Kingpin Lock Tester
TF-0110 Kingpin Gage

GENERAL INFORMATION

1. All fifth wheel maintenance, adjustment and rebuilding must be performed by a qualified person using proper tools and safe procedures. For more information, refer to Holland Publication XL-FW303 Fifth Wheel Maintenance Procedures.
2. Do not modify or add to the product.
3. Use only genuine Holland parts.
4. Wear safety goggles during installation, removal and rebuilding.
5. Never strike any part of the item with a steel hammer.
6. Do not weld on this product without written permission from the factory.
7. Observe standard precautions when lifting.
8. Refer to Holland Publication FW 130 for description and instructions for Holland TF-TLN-1000 Kingpin Lock Tester.

9. Do not deviate from these instructions. Any changes or deviations will void all warranties, expressed or implied, unless written consent is first obtained from the factory.
10. Check to see that all parts included in the kit are enclosed in the box.



This equipment must not be used or maintained in a careless manner.

These products are covered by Holland's Commercial Products Warranty. Holland reserves the right, without giving prior notice, to change specifications and dimensions as designs are altered or improved.



GO THE DISTANCE.

HOLLAND USA, INC.
1950 Industrial Blvd. • P.O. Box 425 • Muskegon, MI 49443-0425
Phone 888-396-6501 • Fax 800-356-3929
www.thehollandgroupinc.com

Copyright © January 2002 • The Holland Group, Inc.

Holland USA, Inc. Facilities:

Denmark, SC Muskegon, MI
Dumas, AR Warrenton, MO
Holland, MI Whitehouse Station, NJ
Milpitas, CA Wylie, TX

Ph: 888-396-6501 Fax: 800-356-3929

Holland International, Inc.

Holland, MI
Phone: 616-396-6501
Fax: 616-396-1511

Holland Hitch of Canada, Ltd.

Woodstock, Ontario • Canada
Phone: 519-537-3494
Fax: 800-565-7753

Holland Equipment, Ltd.

Norwich, Ontario • Canada
Phone: 519-863-3414
Fax: 519-863-2398

Holland Hitch Western, Ltd.

Surrey, British Columbia • Canada
Phone: 604-574-7491
Fax: 604-574-0244