

# FIFTH WHEELS

## TROUBLESHOOTING GUIDE

# TROUBLESHOOTING GUIDE



### Electronic Lock Indicator 12- and 24-volt system



FIGURE 1

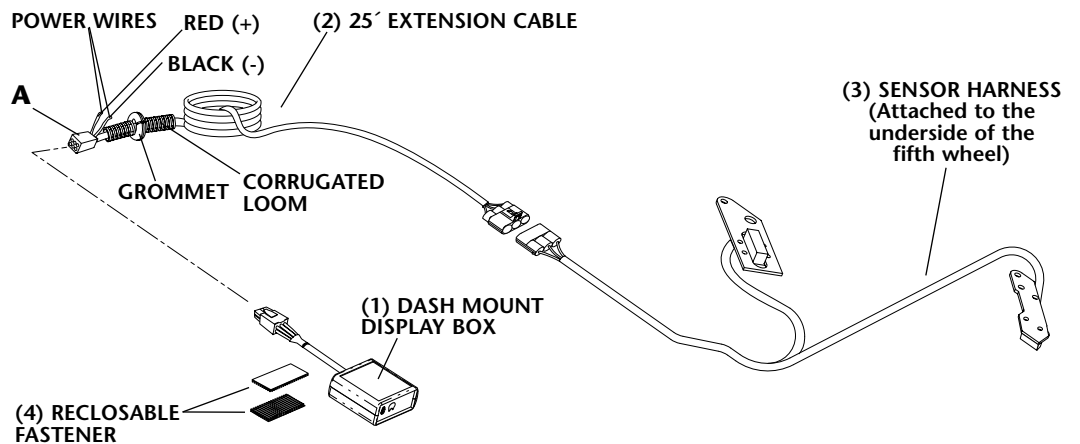

### REPLACEMENT PARTS LIST:

ITEM	PART NO.	QTY.	DESCRIPTION
1	XB-09776-1	1	Display Box (12-volt) <b>OR</b>
	XB-09776-2	1	Display Box (24-volt)
2	XB-09656-1	1	Extension Cable (Includes grommet and corrugated Loom)
3	RK-09922-L	1	Sensor Harness and Hardware (Left Hand) <b>OR</b>
	RK-09922	1	Sensor Harness and Hardware (Right Hand)
4	XB-09782	2	Reclosable Fastener

The ELI system is essentially made up of three components: the display box, the extension cable and the sensor harness. The purpose of this trouble shooting guide is to help determine if there is a problem with any of these three components.

The Error Code Diagnostics sheet that came with the ELI should be used first and the DRIVER **and** TECHNICIAN instructions should be followed. If a problem still persists such that the ELI display does not match the actual coupling status of the fifth wheel, proceed with the following Steps **in order**.

*U.S. Patent #5861802, D442971, 6285278, and other patents pending.*

## 1. NO POWER (The ELI display does not turn on)

- Check that the ignition switch is on and power is going to the terminal where the red power wire is connected.
- Check to make sure the fuse is not blown. The fuse is located at the RED power wire on the extension cable (see **FIGURE 1**) If the fuse is blown replace it with a Type AGC inline 1-amp fuse.
- Check that the 2-wire power cable is connected to a 12 volt power supply (24 volts in Europe) with the RED wire connected to the positive (+) terminal and the BLACK wire connected to the ground (-) terminal. Refer to the Installation Instructions provided with the ELI for proper installation procedures.

**FIGURE 2**

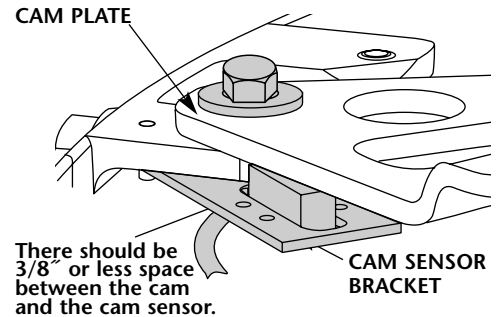

## 2. INITIAL INSPECTION

- Lock the fifth wheel top plate using a Holland lock tester TF-TLN-5001 or TF-TLN-1000. Flip the top plate upside-down.
- Check to make sure the sensors are free from dirt, debris, metal shavings, etc. Wipe them clean.
- Check to make sure the cam plate (**FIGURE 2**) and the kingpin (**FIGURE 3**) are both within 3/8" of their respective sensor when the top plate is coupled properly. Pull the cam plate by hand away from the sensor as far as possible when checking that distance. The cam must not be able to touch the sensor. The cam sensor bracket may be bent slightly to bring it closer to or further from the cam. The kingpin sensor's position is fixed.

**FIGURE 3**

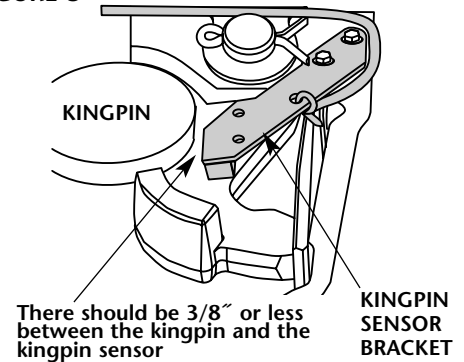

## 3. TESTING THE ENTIRE ASSEMBLY

- When the power is turned on the ELI display should run through a short system check, shown by the brief illumination of the three display icons. After the system check, one of the following displays should appear:



Icon is yellow



Icons are green



Icons are flashing red

If one of these displays does not appear, and Steps 1 and 2 have already been followed, the ELI Display Box should be replaced.

- Unlock the top plate and remove the lock tester. The display should be yellow. If it is not, make sure the sensors are clean and proceed to Step 4.
- Refer to **FIGURES 4** and **5**: Manually check the system by first placing a steel object against the kingpin sensor and then place another steel object against the cam sensor within one second. The sensors are proximity switches that open in the absence of steel and close when steel is present within 3/8" of the sensing zone. The display should show a green fifth wheel and locked padlock icon. If it does, go back to Step 2. If it doesn't, proceed to the next step. When only the kingpin sensor is activated, an error code "7" should appear after one second. When only the cam sensor is activated, error code "0" or "5" should appear.

**FIGURE 4**  
CAM SENSOR

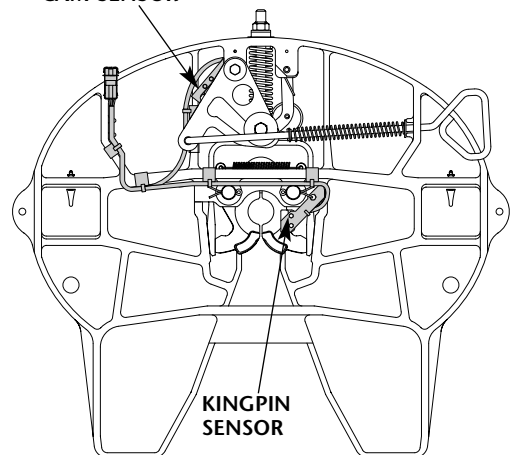

**FIGURE 5**  
PLACE STEEL OBJECTS HERE

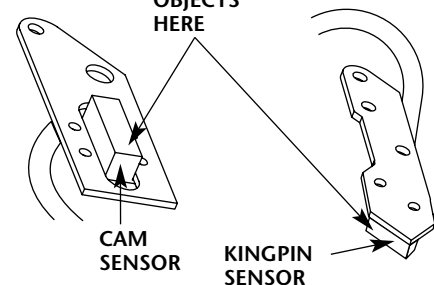

#### 4. TESTING THE SENSOR HARNESS (SEE FIGURE 6 and the Appendix on pg. 4)

- a. Unplug the extension cable from the sensor harness at the fifth wheel. Perform a continuity test between the KINGPIN wire and GROUND (FIGURE 6). Place a steel object against the kingpin sensor at the fifth wheel (FIGURE 4). There should be continuity when the sensor is activated with the steel object and the circuit should be broken when the steel object is removed.
- b. Perform a continuity test between the LOCK wire and GROUND (FIGURE 6) following the same process except placing the steel object against the cam sensor (FIGURE 4).
- c. A Holland Lock Tester may also be used to trip the sensors for the continuity tests.
- d. If either one of the continuity tests failed, the sensor harness should be replaced.
- e. If both continuity tests in STEPS 4a and 4b check out okay, the sensor harness is functioning properly. Proceed to STEP 5.

FIGURE 6

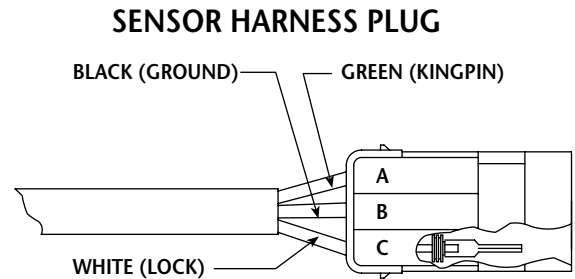

#### 5. TESTING THE EXTENSION CABLE AND SENSOR HARNESS (See FIGURE 7 and the Appendix on pg. 4)

- a. Connect the extension cable and sensor harness that were unplugged in STEP 4.
- b. Turn the ignition switch OFF so there is no power to the ELI. Unplug the extension cable from the display box connector.
- c. Perform a continuity (see APPENDIX on pg 4) test between the KINGPIN wire and SENSOR COMMON (FIGURE 7). Place a steel object against the kingpin sensor at the fifth wheel (FIGURE 4). There should be continuity when the sensor is activated with the steel object and the circuit should be broken when the steel object is removed.
- d. Perform a continuity test between the LOCK wire and SENSOR COMMON (FIGURE 5) following the same process except placing the steel object against the cam sensor (FIGURE 4). A Holland Lock Tester may also be used to lock the fifth wheel and activate the sensors for the continuity tests.
- e. If both continuity tests in STEPS 5b and 5c check out okay, the sensor harness and extension cable are both functioning properly.
- f. If the cable and sensor harness both pass the continuity test, they are functioning properly. If the fifth wheel is functioning properly too, then the display box should be replaced.

FIGURE 7

#### EXTENSION CABLE PLUG

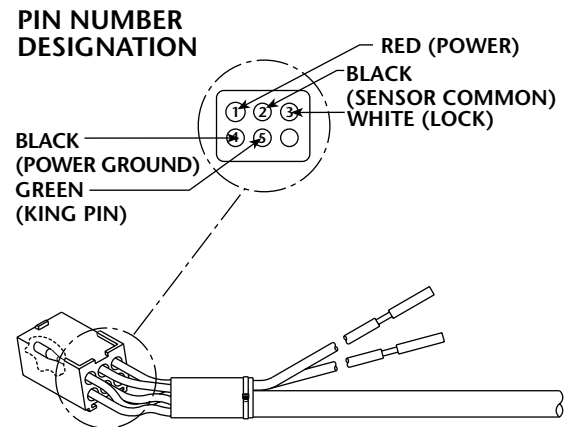

## APPENDIX

A continuity test, performed with an ohmmeter, is a universal test of any wire, connection, or component that will tell if current can flow through it. Continuity is a measure of resistance. A complete circuit has continuity – resistance is nearly zero. An open circuit due to a broken wire or an open switch has no continuity – there is infinite resistance. Always disconnect the power prior to testing. Never make a continuity test on a live circuit.

To test the continuity of any conductor between two points, connect one ohmmeter probe to each test point. If the circuit between points is uninterrupted, the ohmmeter should read nearly zero. If it reads significantly above zero, there may be a poor connection or a damaged wire (or sensor switch) between the test points.

### **CAUTION**

Conducting a continuity test on a live circuit can damage your ohmmeter.



#### **Holland Hitch Company Divisions:**

Holland, MI  
Whitehouse Station, NJ  
Denmark, SC  
Wylie, TX  
Milpitas, CA  
Phone: 888-396-6501  
Fax: 800-769-3299

#### **Holland Binkley Co.**

Warrenton, MO  
Phone: 636-456-3455  
Fax: 636-456-6792

#### **Holland Binkley Co. Axle Products Division**

Delphos, OH  
Phone: 419-692-6015  
Fax: 419-692-0503

#### **Holland Neway International, Inc.**

Muskegon, MI  
Phone: 231-773-3271  
Fax: 231-766-3893

#### **Holland International, Inc.**

Holland, MI  
Phone: 616-396-6501  
Fax: 616-396-1511

#### **Holland Hitch of Canada, Ltd.**

Woodstock, Ontario • Canada  
Phone: 519-537-3494  
Fax: 800-565-7753

#### **Holland Hitch Western, Ltd.**

Surrey, British Columbia • Canada  
Phone: 604-574-7491  
Fax: 604-574-0244

#### **Holland Equipment, Ltd.**

Norwich, Ontario • Canada  
Phone: 519-863-3414  
Fax: 519-863-2398

Copyright © May 2001 • The Holland Group, Inc.