

## 3500 Fifth Wheel Rebuild Procedures

XA-351-A-28-L Series  
Fifth Wheel Top Plate

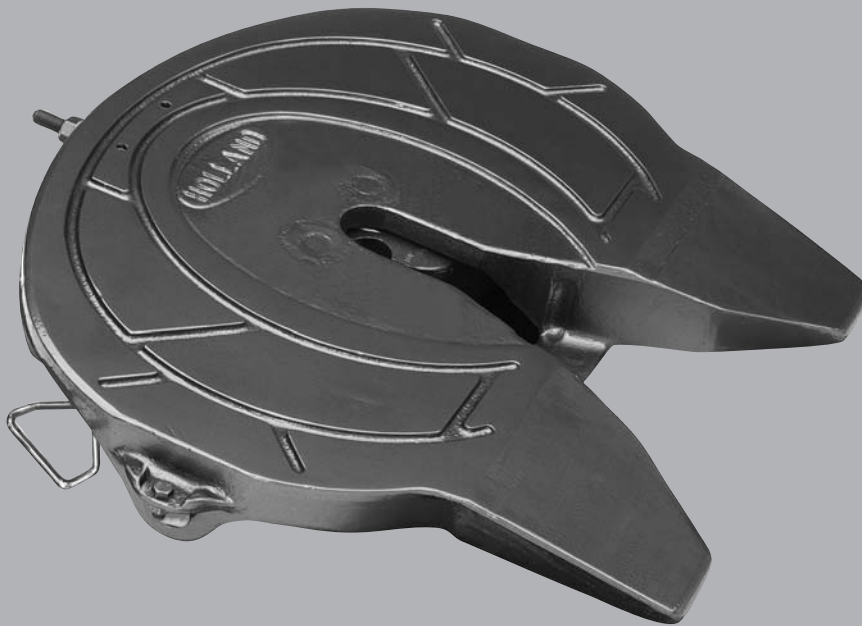

# REBUILD PROCEDURE

## Notes, Cautions, and Warnings

You must read and understand all of the safety procedures presented in this manual before starting any work on the SAF-HOLLAND product.

**NOTE:** In the United States, work shop safety requirements are defined by federal and/or state Occupational Safety and Health Act or equivalent laws in other countries. This manual is written based on the assumption that OSHA or other applicable employee safety regulations are followed by the location where work is performed.

Proper tools must be used to perform the maintenance and repair procedures described in this manual. Many of these procedures require special tools.

Throughout this manual, you will notice the terms "NOTE", "IMPORTANT", "CAUTION", and "WARNING" followed by important product information. So that you may better understand the manual, those terms are as follows:

**NOTE:** Includes additional information to enable accurate and easy performance of procedure.

**IMPORTANT:** Includes additional information that if not followed could lead to hindered product performance.

### CAUTION

Used without the safety alert symbol, indicates a potentially hazardous situation which, if not avoided, may result in property damage.

### ⚠ CAUTION

Indicates a potentially hazardous situation which, if not avoided, may result in minor or moderate injury.

### ⚠ WARNING

Indicates a potentially hazardous situation which, if not avoided, could result in death or serious injury.

### ***Fifth Wheel Design and Intended Use:***

1. For pulling trailers with standard SAE kingpins which are in good condition and securely mounted or locked in position in the trailer.
2. Within the capacities stated in SAF-HOLLAND literature.
3. As recommended in SAF-HOLLAND literature (available from [www.safholland.us](http://www.safholland.us)).

### ***Holland Fifth Wheels are NOT Designed or Intended For:***

1. Use with non-SAE kingpins, such as kingpins which are bent, improper size or dimensions, not secured to maintain SAE configuration, or which are installed in warped trailer bolster plates.
2. Tow-away operations which damage or interfere with the proper operation of the fifth wheel.
3. The attachment of lifting devices.
4. The transport of loads in excess of rated capacity.
5. Applications other than recommended.

This manual contains rebuild procedures for the new fifth wheel top plate (XA-351 Series).

### Left Hand (Road Side) Release Rebuild Kit #RK-351-A-28-L

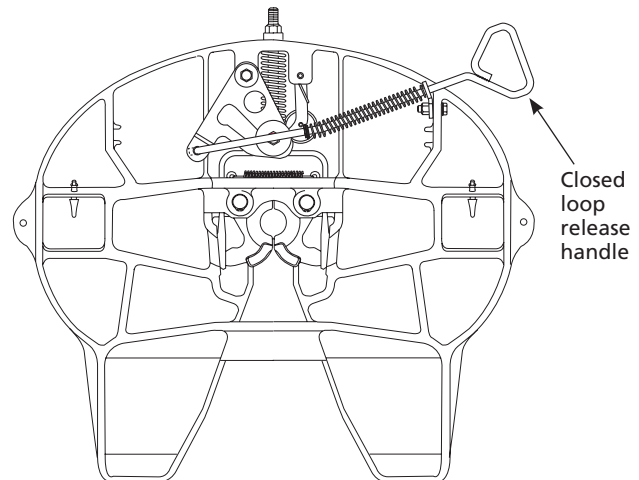

### XA-351 SERIES (Manufactured after 6/1/96) XA-331 SERIES

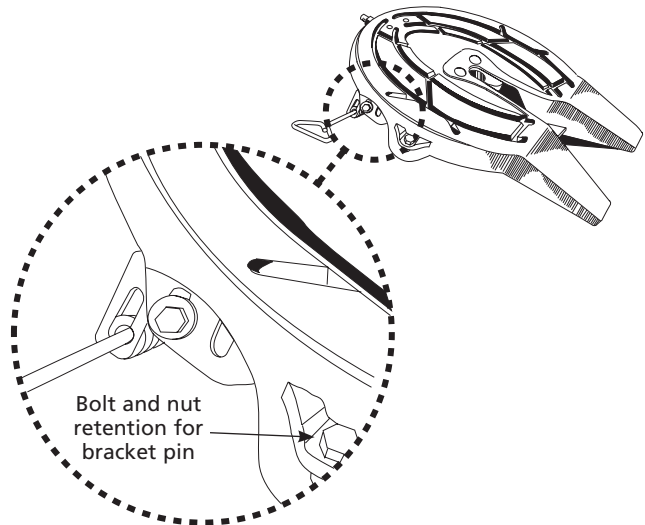

### ⚠ WARNING

Before attempting any repair procedures you must read and understand the following:

- **DO NOT** attempt to rebuild any XA-351 fifth wheel without following the instructions contained in this manual.
- **DO NOT** modify, change, or add to the product. Use only genuine Holland parts.
- Perform all procedures in a lighted area clear of obstacles and other personnel.
- Always wear safety goggles during removal, installation, or service procedures. **DO NOT** strike any part of the product with a steel hammer.
- Observe standard precautions when lifting.

# XA-351-A-28-L PARTS BREAKDOWN

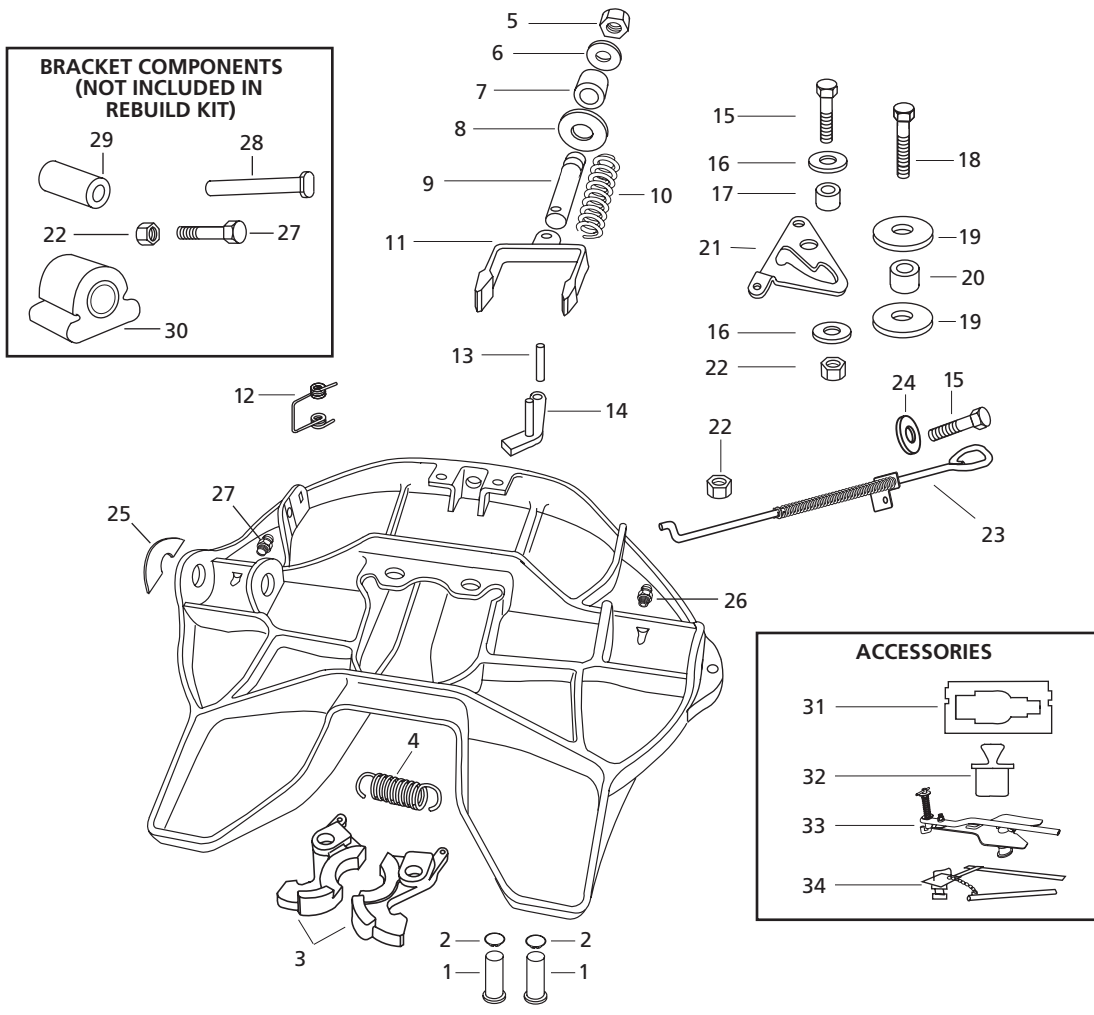

ITEM NO.	PART NO.	NO. REQ.	PART NAME	ITEM NO.	PART NO.	NO. REQ.	PART NAME
1	XA-07292-1	2	Lock pin	18	XB-CX-58-F-134	1	Hex head cap screw (5/8"-18 x 1-3/4")
2	XB-07398	2	Retaining ring	19	XB-07431	2	Washer (2-5/8" x 21/32")
3	XA-07296	1	Lock jaw set	20	XA-1507	1	Roller (5/8" I.D.)
4	XB-07628	1	Extension spring	21	XA-07150-L	1	Cam plate (left-hand)
5	XB-HNH-34-F	1	Locknut (3/4"-16)	22	XB-T-69-A	2	Locknut (1/2"-20) (2 add'l. req'd. for brackets)
6	XB-PW-1316-112	1	Washer (1-1/2" O.D. x 13/16" I.D.)	23	XA-09973	1	Release handle
7	XB-1127	1	Rubber washer	24	XB-PW-1732-1-116	1	Washer (1-1/16" O.D. x 5/8" I.D.)
8	XB-02312	1	Lock adjustment tag	25	XB-07610	1	Operation tag
9	XA-1706	1	Yoke shaft	** 26	XB-H-38	2	Grease zerk
10	XB-1505	1	Compression spring	* 27	XB-C-95	2	Hex head cap screw (1/2"-20 x 1-1/4")
11	XA-07295	1	Yoke	* 28	XE-06356	2	Bracket pin
12	XB-2149	1	Torsion spring	* 29	XB-1604-5	2	Rubber bushing (brackets mfg'd prior to 5/82)
13	XB-21-S-500-2750	1	Roll pin (1/2" x 2-3/4")	* 30	XB-0011-2	2	Rubber bushing (brackets mfg'd after 5/82)
14	XA-3542-L	1	Secondary lock (left-hand)	* 31	TF-0110	1	Kingpin gage
15	XB-2083	2	Hex head cap screw (1/2"-20 x 1-3/4")	* 32	TF-0237	1	2" Lock gage (plug)
16	XB-08559	2	Washer (1-3/4" O.D. x 9/16" I.D.)	* 33	TF-TLN-5001	1	Kingpin lock tester (New)
17	XA-1029	1	Roller (1/2" I.D.)	* 34	TF-TLN-1000	1	Kingpin lock tester (Old)

\* Parts not included in rebuild kit (available from your local Holland distributor.)

\*\* Parts not present on XA-331 Series Low Lube Top Plates

# REBUILD PROCEDURE

## Before Rebuilding

Review the trouble-shooting hints below. You may find that rebuilding is unnecessary. If rebuilding is required, check the front page of this manual to be sure you have the correct kit for your fifth wheel.

### FIFTH WHEEL IS HARD TO HOOK UP TO TRAILER

✓	POSSIBLE CAUSE	REMEDY
<input type="checkbox"/>	Trailer may be too high; the kingpin is not entering the locks properly.	Adjust landing gear so that fifth wheel picks up trailer.
<input type="checkbox"/>	Locks are closed.	Pull release handle.
<input type="checkbox"/>	Accumulated rust or grime interfering with lock operation.	Clean well, then spray a light lubricant or diesel fuel on all moving parts and operate several times.
<input type="checkbox"/>	Bent release handle or kingpin or damaged bolster plate may be interfering with lock movement.	Check and replace as necessary. Check the kingpin with a Holland TF-0110 Kingpin Gage and bolster plate with a 48" straight edge – repair or replace as required.
<input type="checkbox"/>	The locks may be damaged.	Inspect and replace, if required, following the procedures in this manual.
<input type="checkbox"/>	The fifth wheel may need rebuilding.	Follow the procedures contained in this manual using the appropriate rebuilding kit.

### FIFTH WHEEL IS HARD TO UNHOOK FROM TRAILER

✓	POSSIBLE CAUSE	REMEDY
<input type="checkbox"/>	The secondary lock is not released.	<b>If manual secondary</b> – pull release handle and lock open by hooking the handle on the top plate. <b>If automatic secondary</b> – inspect for missing or broken parts and repair or replace as required.
<input type="checkbox"/>	The tractor may be putting pressure against locks.	Set trailer brakes. Back the tractor into the trailer to relieve pressure on fifth wheel locks. Set tractor brakes. Pull release handle.
<input type="checkbox"/>	Rust or grime on locking mechanism.	Clean well, then spray a light lubricant or diesel fuel on all moving parts including release handle and operate several times.
<input type="checkbox"/>	Bent kingpin or damaged bolster plate.	Check the kingpin with a Holland TF-0110 Kingpin Gage and bolster plate with a 48" straight edge – repair or replace as required.
<input type="checkbox"/>	Fifth wheel locks may be adjusted too tight.	Check lock adjustment following the procedures in Section G, page 7.
<input type="checkbox"/>	Release handle will not stay out or must	Replace the cam and release handle spring. Follow the be held out when unlocking. procedures in this manual.

## Rebuild Procedure

### A. Disassembly and Inspection

1. Remove the fifth wheel from the tractor.
2. Place fifth wheel upside down on a flat working surface.
3. Completely disassemble the fifth wheel.  
**DISCARD ALL REMOVED COMPONENTS!  
DO NOT RE-USE ANY PARTS!**

4. Thoroughly steam clean the top plate.
5. Inspect the top plate for cracks and loose lock pin holes. Fifth wheels with cracks or loose lock pin holes must be replaced.



# REBUILD PROCEDURE

**⚠️ WARNING** Do not attempt repair or rebuilding if the top plate is cracked or distorted or if the lock pins do not fit tightly in the top plate as the top plate may fail or the locks may malfunction.

## B. Lock Installation

1. Lubricate the lock pin holes of the lock jaws (Item 3) with Never-Seez (provided in kit). **DO NOT SUBSTITUTE.**

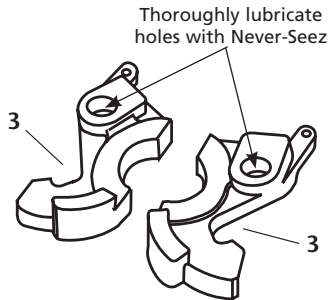

2. Align the lock jaws (Item 3) in the casting, as shown.

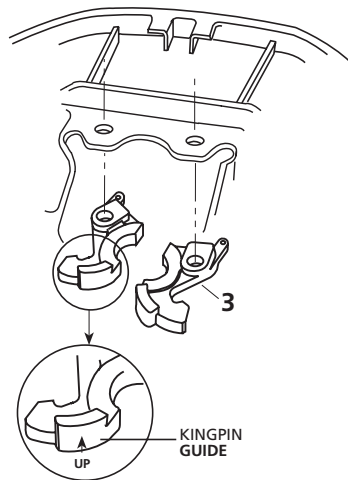

With fifth wheel upside down, position lock jaws so that kingpin guides are facing **up**, as shown.

3. Drive lock pins (Item 1) into casting until heads are flush with casting.

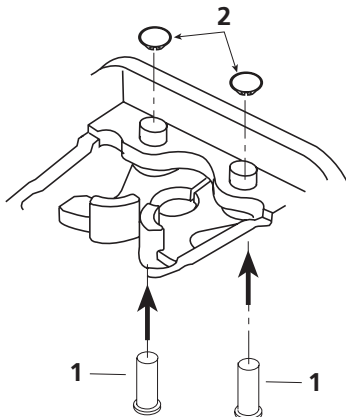

4. Install retaining rings (Item 2) on to lock pins.

5. Position a 2" diameter "plug" into the lock jaws.

A lock gage, Holland part number TF-0237 (Item 37) is available at all Holland distributors.

**WARNING:** You must use a Holland lock gage (TF-0237) or a precision plug that is  $2.000 \pm .005$ " for proper installation of the locking mechanism.

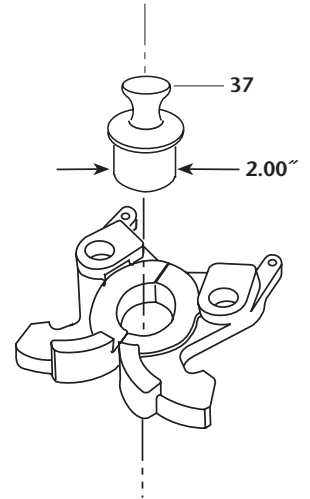

## C. Yoke Installation

1. Lubricate the tips of the yoke with a light grease, as shown.

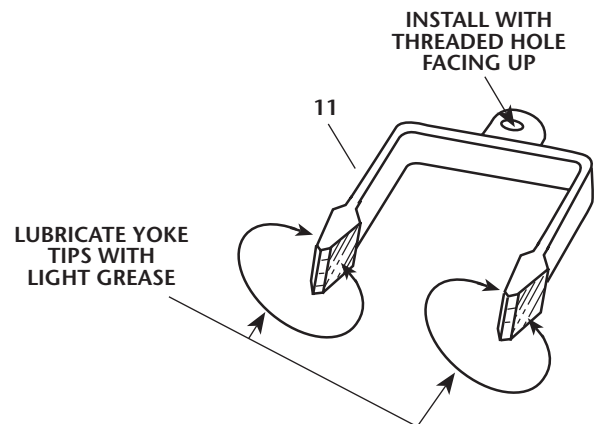

2. With the threaded hole facing up, slide yoke (Item 11) into casting. Tap lightly to seat yoke around locks.

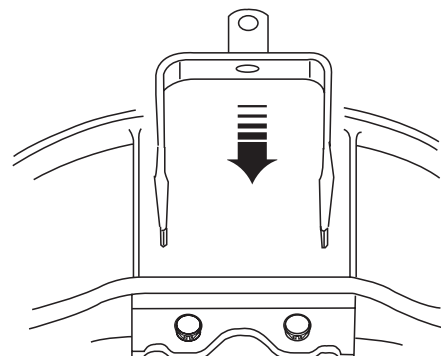

# REBUILD PROCEDURE

## C. Yoke Installation *continued*

- Inspect the amount of yoke tip engagement. Yoke tips must extend flush with the end of the locks and no more than 1/2" past the locks.

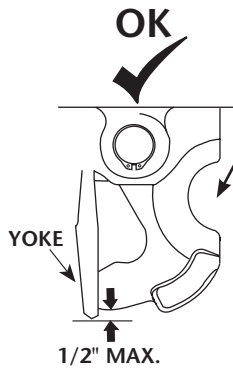
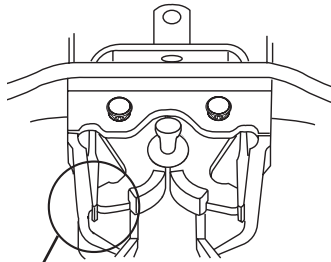

If the new yoke extends more than 1/2" past the locks, **DO NOT USE**. Discard it and order Holland part number XA-07295-THK from your nearest Holland distributor.

- Install lock spring (Item 4), as shown.

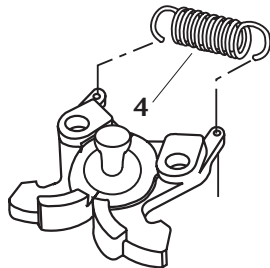

- Install yoke spring (Item 10) as shown below.

- Next, slide the yoke shaft (Item 9) into the casting, through the spring and into the yoke. Align the recessed hole in the shaft with the threaded hole in the yoke

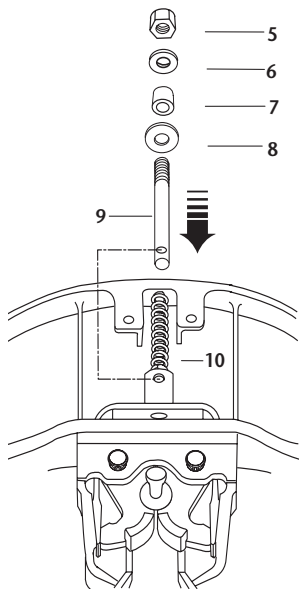

In this order, slide tag (Item 8), rubber washer (Item 7) and 1-1/2" washer (Item 6) onto the yoke shaft. Then start lock nut (Item 5) fingertight.

## D. Cam Plate Installation

- Inspect the cam plate (Item 21L or Item 21R) for burrs. Remove as required.
- Lubricate the cam plate track and pivot hole with a light grease.

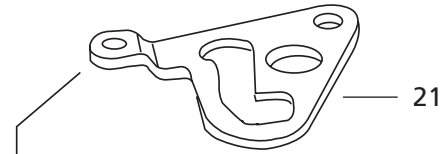

The tab in the cam plate **MUST FACE UP!** as shown.

- Position the cam plate attachment hole over the proper casting lug hole, as shown.

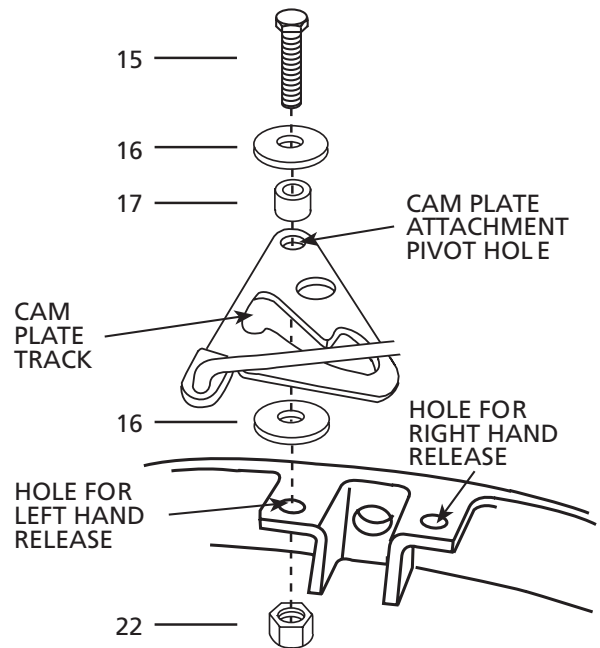

- Slide a 1-3/4" washer (Item 16) between the cam plate and casting lug hole with the rounded side of the washer facing the cam plate.

**NOTE:** When installing washers (Items 16 & 19), the rounded edge of the washers **must** always face the cam plate.

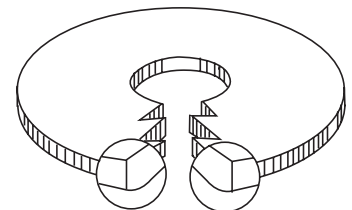



# REBUILD PROCEDURE

## F. Secondary Lock Installation

### Automatic Version

1. Start the roll pin (*Item 13*) into the hole in the top plate opposite the cam attachment bolt.

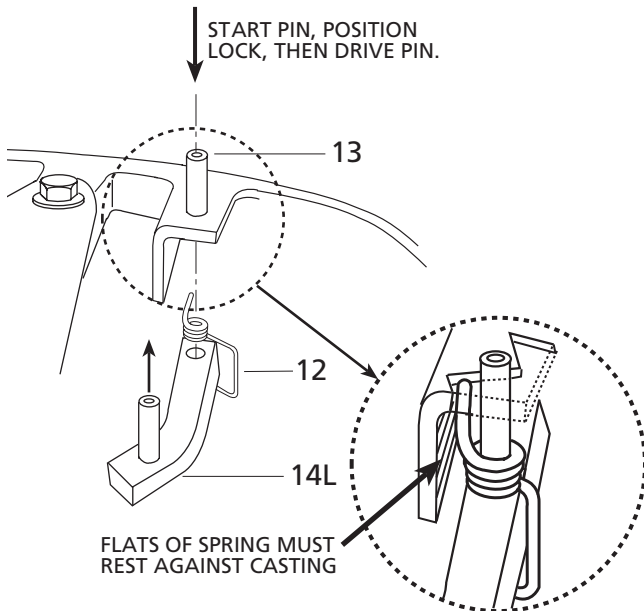

2. Assemble the secondary lock (*Item 14L or 14R*) to the torsion spring (*Item 12*), as shown.
3. Drive the roll pin (*Item 13*) through the spring and lock until flush with the casting.
4. Check the lock spring for tension and lock for free movement.

## G. Lock Adjustment

1. If equipped, pull the secondary release handle (*Item 34*) and hook it on the casting. Next, pull the primary release handle (*Item 23*) to open the locks and remove the 2" plug.

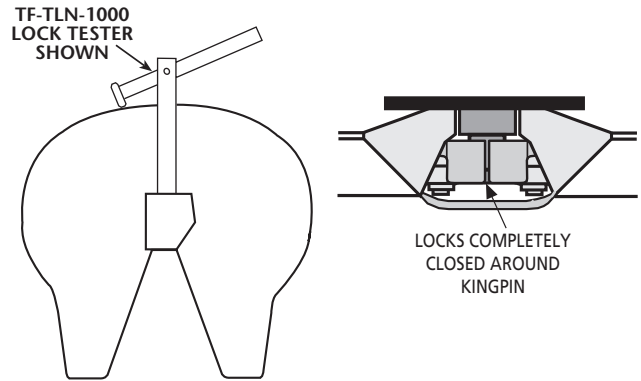

2. Turn the fifth wheel right side up and close the locks using a Holland Lock Tester (*Item 38*). See Holland publication FW130 for operating instructions for Holland TF-TLN-1000 kingpin lock tester.
3. Verify that the locks are completely closed around the kingpin, as shown.
4. Now, alternate tightening the adjustment nut and attempting to rotate the lock tester back and forth, as shown. Continue tightening until the lock tester can be rotated but some resistance is felt in the lock tester.

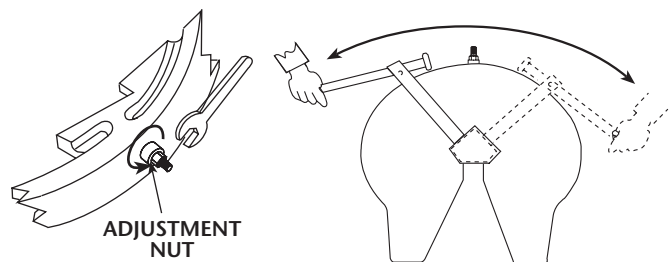

The fifth wheel is properly adjusted when there is resistance between the locks and the lock tester, but the lock tester can still be rotated by hand, as shown.

5. Pull the release handle and remove the lock tester.



# REBUILD PROCEDURE

## H. Operation Check

Before you use your fifth wheel, you must verify that it is operating properly.

1. Open and close the fifth wheel at least three (3) times using a Holland Lock Tester.

Each time you close the locks, verify that the locks have closed completely around the kingpin and that the adjustment nut and rubber bushing are seated snug against the casting, as shown.

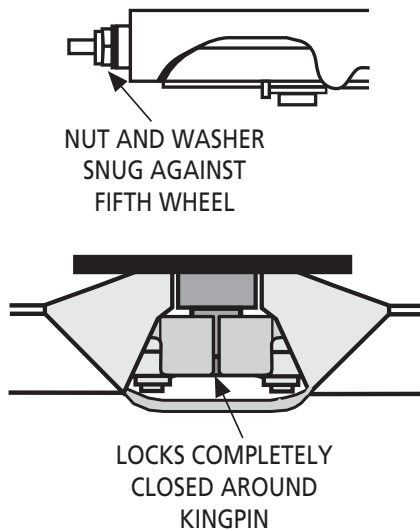

2. Check for resistance between the locks and lock tester one final time, adjust as needed.

The fifth wheel is now ready for operation.

For additional maintenance procedures, refer to SAF-HOLLAND publication XL-FW308-XX, "Fifth Wheel Maintenance Procedures."

**⚠ WARNING** If the fifth wheel does not operate properly, **DO NOT USE IT!** Either disassemble and repeat rebuilding procedures or contact your nearest SAF-HOLLAND representative for assistance. Never use a fifth wheel that does not operate properly.

**THIS PAGE INTENTIONALLY LEFT BLANK**

**THIS PAGE INTENTIONALLY LEFT BLANK**



From fifth wheel rebuild kits to suspension bushing repair kits, SAF-HOLLAND Original Parts are the same quality components used in the original component assembly. SAF-HOLLAND Original Parts are tested and designed to provide maximum performance and durability. Will-fits, look-alikes or worse yet counterfeit parts will only limit the performance potential and could possibly void SAF-HOLLAND's warranty. Always be sure to spec SAF-HOLLAND Original Parts when servicing your SAF, Holland or Neway product.

 <b>WARNING</b>	<b>Failure to properly install, operate, or maintain this fifth wheel could result in tractor and trailer separation causing death or serious injury to others.</b>
