

Troubleshooting Guide

Fifth Wheels

Electronic Lock Indicator



FIGURE 1

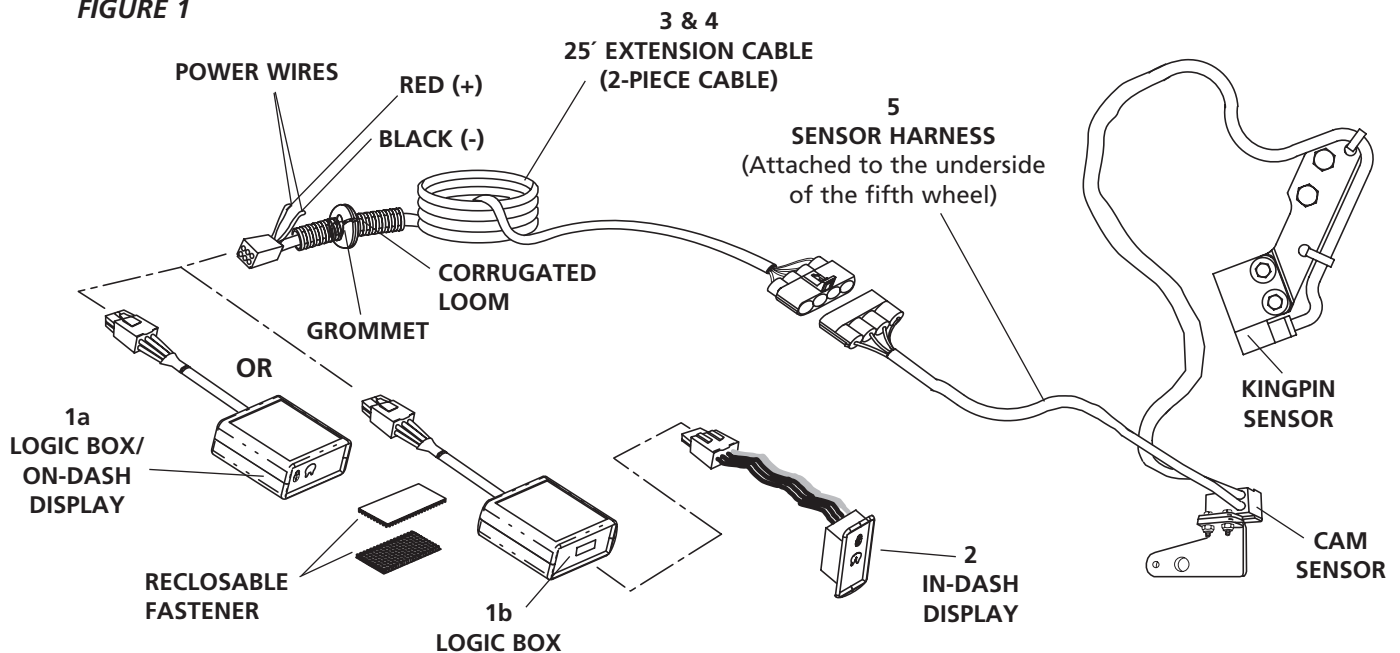

The ELI system is essentially made up of three components: the logic box (and display), the extension cable and the sensor harness. The purpose of this troubleshooting guide is to help determine if there is a problem with any of these three components.

If the display is mounted on the dash, the Error Code Diagnostics sheet that came with the ELI should be used first and the DRIVER *and* TECHNICIAN instructions should be followed. If a problem still persists such that the ELI display does not match the actual coupling status of the fifth wheel, proceed with the following Steps *in order*.

⚠ WARNING The electronic lock indicator is a tractor/trailer fifth wheel coupling aid and is intended as an additional safety check to assure the driver of a safe and complete coupling. It does not eliminate the requirement for a visual inspection of the fifth wheel.

ALWAYS GET OUT OF THE TRACTOR CAB AND VISUALLY INSPECT THE FIFTH WHEEL COUPLING!

U.S. Patent #5861802, D442971, 6285278, and other patents pending.

1. No Power (The ELI display does not turn on)

- Check that the ignition switch is on and power is going to the terminal where the red power wire is connected.
- Check to make sure the fuse is not blown. The fuse is located at the RED power wire on the extension cable (see **FIGURE 1**) If the fuse is blown replace it with a Type AGC inline 1-amp fuse.
- Check that the 2-wire power cable is connected to a 12 volt power supply with the RED wire connected to the positive (+) terminal and the BLACK wire connected to the ground (-) terminal. Refer to the Installation Instructions provided with the ELI for proper installation procedures.

2. Initial Inspection

- Lock the fifth wheel top plate using a Holland lock tester TF-TLN-5001. Flip the top plate upside-down.
- Check to make sure the sensors are free from dirt, debris, metal shavings, etc. Wipe them clean.
- Check to make sure the cam plate (**FIGURE 2**) and the kingpin (**FIGURE 3**) are both within 3/8" of their respective sensor when the top plate is coupled properly. Pull the cam plate by hand away from the sensor as far as possible when checking that distance. The cam must not be able to touch the sensor. The cam sensor bracket may be bent slightly to bring it closer to or further from the cam. The kingpin sensor's position is fixed.

3. Testing the Entire Assembly

- When the power is turned on the ELI display should run through a short system check, shown by the brief illumination of the three display icons. After the system check, one of the following displays should appear:

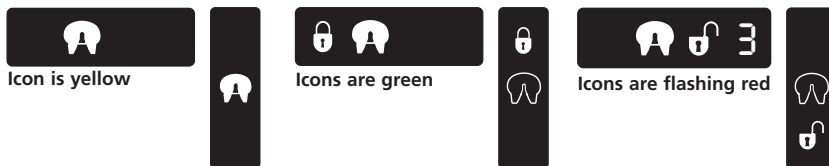

If one of these displays does not appear, and *Steps 1* and *2* have already been followed, the ELI Display Box should be replaced.

- Unlock the top plate and remove the lock tester. The display should be yellow. If it is not, make sure the sensors are clean and proceed to *Step 4*.
- Refer to **FIGURES 4** and **5**: Manually check the system by first placing a steel object against the kingpin sensor and then place another steel object against the cam sensor within one second. The sensors open in the absence of steel and close when steel is present within 3/8" of the sensing zone. The display should show a green locked padlock icon. If it does, go back to *Step 2*. If it doesn't, proceed to the next step. When only the kingpin sensor is activated, an error code "7" should appear after one second. When only the cam sensor is activated, error code "0" or "5" should appear.

FIGURE 2



There should be a gap of 3/8" or less between the cam plate and the cam sensor

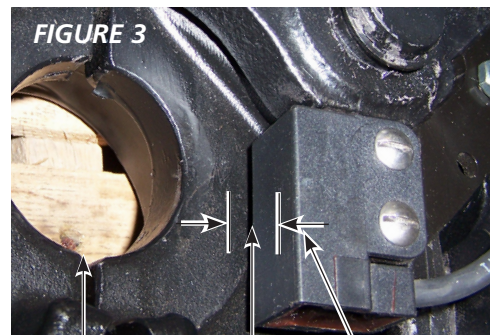

There should be a gap of 3/8" or less between the kingpin and the kingpin sensor

FIGURE 4

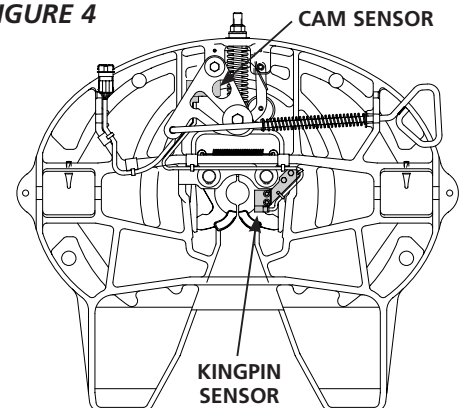
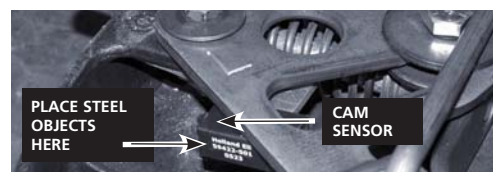

FIGURE 5



4. Testing the Sensor Harness (See Figure 6)

Confirming the Rest of the System Functions

- a. Unplug the extension cable from the sensor harness at the fifth wheel.
- b. Turn power on to the display, illuminating the fifth wheel icon yellow.
- c. Make a jumper connection between the KINGPIN wire and SENSOR COMMON (**FIGURE 6**). The display should be flashing red. Disconnect the jumper—the display icon returns to yellow.
- d. Make a jumper connection between the CAM/LOCK wire and SENSOR COMMON (**FIGURE 6**). The display should be flashing red. Disconnect the jumper—the display icon returns to yellow.
- e. Using a DC voltmeter, check for +5VDC between SENSOR COMMON and SENSOR +5VDC (**FIGURE 6**).
- f. If everything checks out from a through e above, the problem is in the harness. Replace harness and return to **STEP 3**.

FIGURE 6

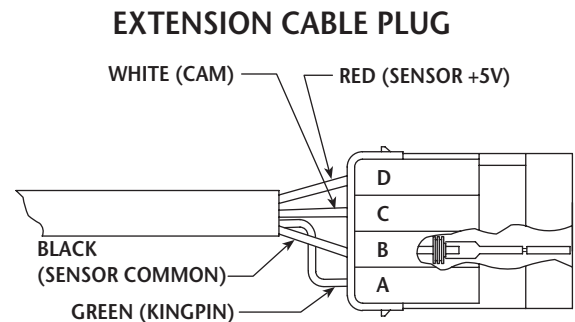

Replacement Parts List (See Figure 1)

ITEM	PART NO.	QTY.	DESCRIPTION
1a	XB-10758-12	1	Logic Box/On-Dash Display
1b	XB-10759-12	1	Logic Box For Use With In-Dash Display
2	XB-10760-V	1	In-Dash Display
3	XB-10782	1	Cab Extension Cable
4	XB-10781	1	Chassis Extension Cable
5a	RK-10903-L	1	Sensor Harness Kit (Left Hand)
5b	RK-10903-R	1	Sensor Harness Kit (Right Hand)

