

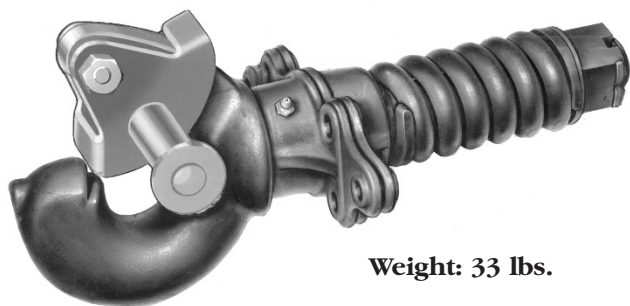

GO THE DISTANCE.

# PH-T-100-A

## PH-T-100-A SPECIFICATIONS



Weight: 33 lbs.



**Swivel type pintle hook with spring cushion. Swivel action provides torsional relief, and spring cushion provides some shock absorption at the coupling.**

**4,000 lbs. Maximum Vertical Load**  
**20,000 lbs. Maximum Gross Trailer Weight**

### SAE J847 Information:

Type I - not applicable. Type II - 20,000 lbs.



### WARNING

Maintain adequate vertical (tongue) load to properly control the trailer (generally 10%) but do not exceed the above rated capacities.

### TOWING APPLICATIONS:

Trailers and equipment designed for over-the-road towing within the stated capacities. Use **ONLY** with non-swivel type drawbar. For off-road applications, reduce the capacities above by 25%. This pintle hook is well suited for use in the utility and construction industries.

### DRAWBAR EYE DIMENSIONS:

2.38" to 3" I.D. with 1.25" to 1.63" diameter section.

### MOUNTING:

1. Use a mounting structure of sufficient strength to support the rated capacity of the pintle hook in accordance with SAE J849 and SAE J847 respectively.
2. Use the hole pattern described on the reverse.
3. Remove cotter pin (XB-T-60), nut (XA-T-9N), washer (XA-T-56), spring (XB-T-52) and both flanges (XA-T-92 and XA-T-92-A2).
4. Install flanges using (6) .5" grade 8 fasteners, properly tightened.
5. Install pintle, spring, washer and nut. Tighten nut until snug against the spring. Turn nut an additional 1/2 turn and install cotter pin in the nut castellation. Spread cotter pin.

### OPERATING INSTRUCTIONS:

1. Before operating, inspect for proper operation, worn, damaged or missing parts and secure mounting. Correct as required before use.
2. Make sure the pintle is in the proper coupling position as shown above (latch on top).
3. Open latch (XA-T-93-A1) by pulling plunger (A) and rotating latch open.
4. Position drawbar eye over the horn of the pintle and lower into place.



### WARNING

**DO NOT** damage the latch. Be particularly careful with the drawbar when coupling and uncoupling.

5. To close the latch, pull plunger, rotate latch closed and release plunger. Plunger must be fully engaged to lock the latch.



### WARNING

Other steps and inspections are also required. Consult OSHA and D.O.T. regulations and American Trucking Association for complete coupling and uncoupling procedures. These cover items such as cargo securement, brakes, lights, safety chains, and other important requirements.

### MAINTENANCE:

For proper performance, the following maintenance steps should be performed every 30,000 miles or 3 months, whichever comes first.

1. Clean and check for proper operation. Inspect for worn, damaged or missing parts. Replace as required using only Holland parts.
2. Inspect, in particular, the coupling contact area and periodically disassemble to inspect for wear on the shank and mounting flanges. Replace any component when wear exceeds 1/8" (0.125") from the original surface profile.
3. Regularly lubricate latch pivot with a light oil lubricant. Apply a small quantity of grease through the grease fittings in the mounting flanges.
4. Check mounting fasteners for proper torque. Retighten nut (XA-T-9N) as instructed in Step 5, "Mounting", above.

**GENERAL INFORMATION:**

1. Do not modify or add to the product.
2. Wear safety goggles during installation, removal and servicing.
3. Never strike any part of the item with a steel hammer.
4. Do not weld on this product without written consent from the factory.



This product must not be used or maintained in a careless manner.

This product is covered by Holland's Commercial Products Warranty. Holland reserves the right, without giving prior notice, to change specifications and dimensions as designs are altered or improved.

**PH-T-100-A**

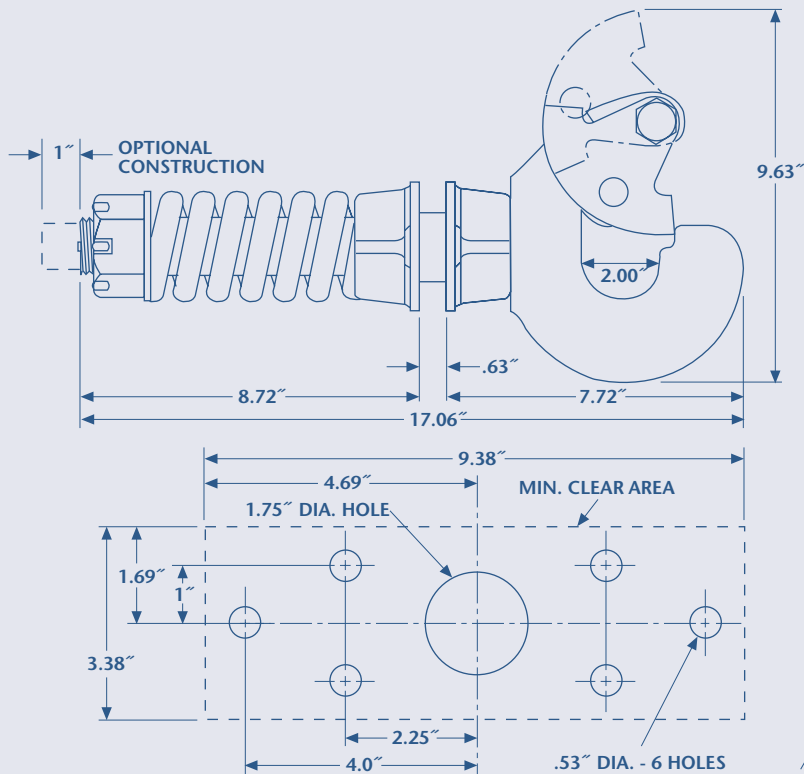

**ALL DIMENSIONS SHOWN ARE NOMINAL**

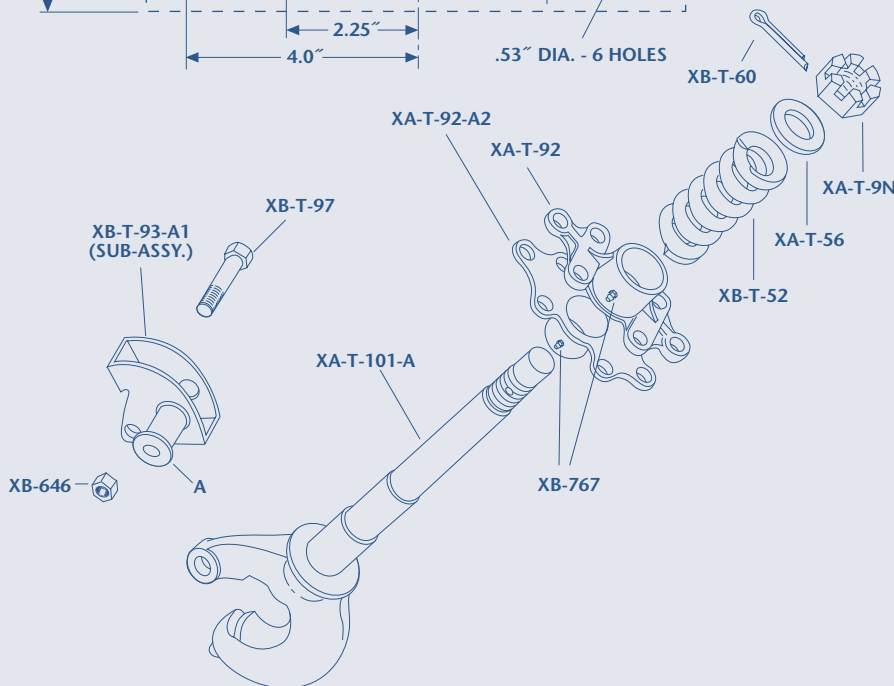

Copyright © July 2000 • The Holland Group, Inc.

**Holland Hitch Company Divisions:**

Holland, MI  
Whitehouse Station, NJ  
Denmark, SC  
Wylie, TX  
Milpitas, CA  
Phone: 888-396-6501  
Fax: 800-769-3299

**Holland Binkley Co.**

Warrenton, MO  
Phone: 636-456-3455  
Fax: 636-456-6792

**Holland Binkley Co. Axle Products Division**

Delphos, OH  
Phone: 419-692-6015  
Fax: 419-692-0503

**Holland Neway International, Inc.**

Muskegon, MI  
Phone: 231-773-3271  
Fax: 231-766-3893

**Holland International, Inc.**

Holland, MI  
Phone: 616-396-6501  
Fax: 616-396-1511

**Holland Hitch of Canada, Ltd.**

Woodstock, Ontario • Canada  
Phone: 519-537-3494  
Fax: 800-565-7753

**Holland Hitch Western, Ltd.**

Surrey, British Columbia • Canada  
Phone: 604-574-7491  
Fax: 604-574-0244

**Holland Equipment, Ltd.**

Norwich, Ontario • Canada  
Phone: 519-863-3414  
Fax: 519-863-2398